



REQUEST for PROPOSAL #893
PROFESSIONAL, TECHNICAL AND EXPERT SERVICES

Clark County Washington

RELEASE DATE: WEDNESDAY, MAY 15, 2024
DUE DATE: WEDNESDAY, JUNE 5, 2024 by 1:30 pm

Request for Proposal for:

LACAMAS REGIONAL PARK ACCESS ROAD BRIDGE REPLACEMENT

SUBMIT:

One (1) Original
Three (3) Complete Copies

of the Proposal to:

<u>Shipping Method of your Choice or Hand Delivery</u>	<u>United States Postal Service</u>
Clark County ATTN: Office of Purchasing 1300 Franklin Street, 6 th Floor, Suite 650 Vancouver WA 98660 564-397-2323	Clark County ATTN: Office of Purchasing PO Box 5000 Vancouver WA 98666-5000 564-397-2323

Office Hours: 8:00 am – 3:00 pm, Monday – Friday, except Legal Holidays.

No electronic submissions.

****Proposals must be delivered to the Purchasing office – No Exceptions**

****Proposals must be date and time stamped by Purchasing staff by 1:30 pm on due date.**

****Proposal shall be sealed and clearly marked on the package cover with RFP #, Title & Company Name**

Refer Questions to Project Manager:

Evelyn Ives
Project Manager | Public Works Parks and Lands Division
Evelyn.Ives@clark.wa.gov
564-397-5885

ADMINISTRATIVE REQUIREMENTS - Contractors shall comply with all management and administrative requirements established by Washington Administrative Code (WAC), the Revised Code of the State of Washington (RCW), and any subsequent amendments or modifications, as applicable to providers licensed in the State of Washington.

ALL proposals submitted become the property of Clark County. It is understood and agreed that the prospective Proposer claims no proprietary rights to the ideas and written materials contained in or attached to the proposal submitted. Clark County has the right to reject or accept proprietary information.

AUTHORSHIP - Applicants must identify any assistance provided by agencies or individuals outside the proposers own organization in preparing the proposal. No contingent fees for such assistance will be allowed to be paid under any contract resulting from this RFP.

CANCELLATION OF AWARD - Clark County reserves the right to immediately cancel an award if the contractual agreement has not been entered into by both parties or if new state regulations or policy make it necessary to change the program purpose or content, discontinue such programs, or impose funding reductions. In those cases where negotiation of contract activities are necessary, Clark County reserves the right to limit the period of negotiation to sixty (60) days after which time funds may be unencumbered.

CONFIDENTIALLY - Proposer shall comply with all applicable state and federal laws governing the confidentiality of information.

CONFLICT OF INTEREST - All proposals submitted must contain a statement disclosing or denying any interest, financial or otherwise, that any employee or official of Clark County or the appropriate Advisory Board may have in the proposing agency or proposed project.

CONSORTIUM OF AGENCIES - Any consortium of companies or agencies submitting a proposal must certify that each company or agency of the consortium can meet the requirements set forth in the RFP.

COST OF PROPOSAL & AWARD - The contract award will not be final until Clark County and the prospective contractor have executed a contractual agreement. The contractual agreement consists of the following parts: (a) the basic provisions and general terms and conditions, (b) the special terms and conditions, (c) the project description and goals (Statement of Work), and (d) the budget and payment terms. Clark County is not responsible for any costs incurred prior to the effective date of the contract. Clark County reserves the right to make an award without further negotiation of the proposal submitted. Therefore, the proposal should be submitted in final form from a budgetary, technical, and programmatic standpoint.

DISPUTES - Clark County encourages the use of informal resolution to address complaints or disputes arising over any actions in implementing the provisions of this RFP. Written complaints should be addressed to Clark County – Purchasing, P.O. Box 5000, Vancouver, Washington 98666-5000.

DIVERSITY IN EMPLOYMENT AND CONTRACTING REQUIREMENTS - It is the policy of Clark County to require equal opportunity in employment and services subject to eligibility standards that may be required for a specific program. Clark County is an equal opportunity employer and is committed to providing equal opportunity in employment and in access to the provision of all county services. Clark County's Equal Employment Opportunity Plan is available at <http://www.clark.wa.gov/hr/documents.html>. This commitment applies regardless of race, color, religion, creed, sex, marital status, national origin, disability, age, veteran status, on-the-job injury, or sexual orientation. Employment decisions are made without consideration of these or any other factors that are prohibited by law. In compliance with department of Labor Regulations implementing Section 504 of the rehabilitation Act of 1973, as amended, no qualified handicapped individual shall be discriminated against in admission or access to any program or activity. The prospective contractor must agree to provide equal opportunity in the administration of the contract, and its subcontracts or other agreements.

MUNICIPAL RESEARCH and SERVICE CENTER - Clark County (WA) contracts with the Municipal Research and Service Center (MRSC) to maintain our Consultant, Small Works and Vendor rosters. To be eligible to participate in this Clark County public solicitation and the resulting contract, your business must be registered with the MRSC Rosters. Failure to register may result in your proposal being marked nonresponsive. Be sure to select Clark County in your application. If you have questions about the registration process, contact the MRSC Rosters at 206-436-3798 or <https://mrsrosters.org/businesses/business-membership/>

INDEPENDENT PRICE DETERMINATION - The prospective contractor guarantees that, in connection with this proposal, the prices and/or cost data have been arrived at

independently, without consultation, communication, or agreement for the purpose of restricting competition. This does not preclude or impede the formation of a consortium of companies and/or agencies for purposes of engaging in jointly sponsored proposals.

INTERLOCAL AGREEMENT - Clark County has made this RFP subject to Washington State statute RCW 39.34. Therefore, the proposer may, at the proposers option, extend identical prices and services to other public agencies wishing to participate in this RFP. Each public agency wishing to utilize this RFP will issue a purchase order (or contract) binding only their agency. Each contract is between the proposer and the individual agency with no liability to Clark County.

LIMITATION - This RFP does not commit Clark County to award a contract, to pay any costs incurred in the preparation of a response to this RFP, or to procure or contract for services or supplies.

LATE PROPOSALS - A proposal received after the date and time indicated above will not be accepted. No exceptions will be made.

ORAL PRESENTATIONS - An oral presentation may be required of those prospective contractors whose proposals are under consideration. Prospective contractors may be informed that an oral presentation is desired and will be notified of the date, time and location the oral presentation is to be conducted.

OTHER AUDIT/MONITORING REQUIREMENTS - In addition, auditing or monitoring for the following purposes will be conducted at the discretion of Clark County: Fund accountability; Contract compliance; and Program performance.

PRICE WARRANT - The proposer shall warrant that the costs quoted for services in response to the RFP are not in excess of those which would be charged any other individual or entity for the same services performed by the prospective contractor, in a similar socioeconomic, geographical region.

PROTESTS - Must be submitted to the Purchasing Department.

PUBLIC SAFETY - May require limiting access to public work sites, public facilities, and public offices, sometimes without advance notice. The successful Proposer's employees and agents shall carry sufficient identification to show by whom they are employed and display it upon request to security personnel. County project managers have discretion to require the successful Proposer's employees and agents to be escorted to and from any public office, facility or work site if national or local security appears to require it.

ACCEPTANCE or REJECTION OF PROPOSALS - Clark County reserves the right to accept or reject any or all proposals received as a result of this RFP, to negotiate with any or all prospective contractors on modifications to proposals, to waive formalities, to postpone award, or to cancel in part or in its entirety this RFP if it is in the best interest of Clark County to do so.

SUBCONTRACTING - No activities or services included as a part of this proposal may be subcontracted to another organization, firm, or individual without the approval of Clark County. Such intent to subcontract shall be clearly identified in the proposal. It is understood that the contractor is held responsible for the satisfactory accomplishment of the service or activities included in a subcontract.

VERBAL PROPOSALS - Verbal proposals will not be considered in making the award of any contract as a result of this RFP.

WORKERS COMPENSATION INSURANCE – The contractor shall comply with R.C.W. Title 51- with minimum coverage limits of \$500,000 for each accident, or provide evidence that State law does not require such coverage.

FOR ALTERNATIVE FORMATS
Clark County ADA Office: V: 564-397-2322
ADA@clark.wa.gov

Request for Proposals Table of Contents

PART I	PROPOSAL REQUIREMENTS
	Section IA: General Information
	1. Introduction
	2. Background
	3. Scope of Project
	4. Project Funding
	5. Title VI Statement
	6. Timeline for Selection
	7. Employment Verification
	Section IB: Work Requirements
	1. Required Services
	2. County Performed Work
	3. Deliverables and Schedule
	4. Place of Performance
	5. Period of Performance
	6. Prevailing Wage
	7. Debarred / Suspended
	8. Americans with Disabilities Act (ADA) Information
	9. Public Disclosure
	10. Insurance/Bond
	11. Plan Holders List
PART II	PROPOSAL PREPARATION AND SUBMITTAL
	Section IIA: Pre-Submittal Meeting/Clarification
	1. Pre-Submittal Meeting
	2. Proposal Clarification
	Section IIB: Proposal Submission
	1. Proposals Due
	2. Proposal
	Section IIC: Proposal Content
	1. Cover Sheet
	2. Project Team
	3. Management Approach
	4. Respondent's Capabilities
	5. Project Approach and Understanding
	6. Proposed Cost
PART III	PROPOSAL EVALUATION & CONTRACT AWARD
	Section IIIA: Proposal Review and Selection
	1. Evaluation and Selection
	2. Evaluation Criteria Scoring
	Section IIIB: Contract Award
	1. Consultant Selection
	2. Contract Development
	3. Award Review
	4. Orientation/Kick-off Meeting
ATTACHMENTS	A: Proposal Cover Sheet
	B: Letter of Interest
	C: Certification Regarding Debarment, Suspension and Other Responsibility Matters Form
	D: Vicinity Map of Bridge Location
	E: Bridge Inspection Report
	F: Bridge Technical Memo and Load Rating

Request for Proposal #893
Lacamas Regional Park Access Road Bridge Replacement

- G. Bridge Replacement and Repair Options for Lacamas Creek
- H. County Wetland/Habitat Predetermination Report
- I. Example: Professional Services Agreement

Request for Proposal #893

Lacamas Regional Park Access Road Bridge Replacement

Part I Proposal Requirements

Section IA	General Information
1. Introduction	<p>Clark County Parks and Lands is soliciting qualification submittals for bridge design and environmental services for a multiuse bridge crossing of Lacamas Creek within the County's Lacamas Regional Park. The bridge is used primarily by park users for biking and hiking, and secondarily by vehicles (for park maintenance, emergency response, and dam maintenance). The County is seeking a firm or team of firms who are experienced in bridge design, environmental permitting and construction management to develop plans, specifications, engineer's estimates, and applicable environmental permitting documentation to replace this aging bridge.</p> <p>Clark County (WA) contracts with the Municipal Research and Service Center (MRSC) to maintain our Consultant, Small Works and Vendor Rosters. To be eligible to participate in this Clark County public solicitation and the resulting contract your business must be registered with the MRSC Rosters. Failure to register may result in your proposal being marked nonresponsive. Be sure to select Clark County in your application. If you have questions about the registration process, contact the MRSC Rosters at 206-436-3798 or https://mrscrosters.org/businesses/business-membership/</p> <p>If your company contact details <i>are not</i> on the Plan Holder List at https://clark.wa.gov/internal-services/request-proposal-1 Attachment B, Letter of Interest must be submitted to participate in this RFP.</p> <p>Proposers shall respond to all sections to be considered.</p> <p>Clark County has made this Request for Proposal subject to Washington State statute RCW 39.34 Interlocal Cooperation Act. The proposer may opt to extend identical services and prices to qualified public agencies. Each contract is between the proposer and individual agency binding only their agency, with no liability to Clark County.</p>
2. Background	<p>A map of the bridge's location is included in Attachment D. The bridge's structure was identified as critically deficient during 2023 when the bridge was inspected and load rated; the evaluation reports are included in Attachments E and F. In addition to bridge inspection and load rating, a consultant provided recommendations for bridge replacement, which are provided in Attachment G. A Clark County Community Development biologist has completed a wetland/habitat predetermination report for two areas of the park, including the area cover under this bridge replacement project. The predetermination report is included in Attachment H.</p>
3. Scope of Project	<p>Anticipated Consultant Services include:</p> <ul style="list-style-type: none"> • Topographic survey • Hydraulic engineering evaluations of Lacamas Creek • Structural engineering • Archaeological/cultural resources predetermination report and potential survey, as needed • Identify and prepare permitting documents that meet the requirements of applicable federal, state, and local regulations. These will be reviewed and submitted by the County

Request for Proposal #893
Lacamas Regional Park Access Road Bridge Replacement

	<ul style="list-style-type: none"> • Plans, Specifications, and Estimates at permit-level, 90%, 95%, and final construction-ready packages for replacing the Lacamas Creek crossing • Construction engineering support, including but not limited to: <ul style="list-style-type: none"> ○ Review and response to contractor submittals ○ Response to requests for information (RFI) ○ Construction observation/meetings, as needed and/or directed by the County
<p>4. Project Funding</p>	<p>This project’s budget will use Clark County Parks and Lands funding. The anticipated cost for the services described herein is \$200,000.</p>
<p>5. Title VI Statement</p>	<p><u>Title VI Statement</u> Clark County, in accordance with the provisions of Title VI of the Civil Rights Act of 1964 (78 Stat. 252, 42 U.S.C. §§ 2000d to 2000d-4) and the Regulations, hereby notifies all bidders that it will affirmatively ensure that any contract entered into pursuant to this advertisement, disadvantaged business enterprises will be afforded full and fair opportunity to submit bids in response to this invitation and will not be discriminated against on the grounds of race, color, or national origin in consideration for an award.</p> <p>El Condado de Clark, de acuerdo con las disposiciones del Título VI de la Ley de Derechos Civiles de 1964 (78 Stat. 252, 42 U.S.C. §§ 2000d a 2000d-4) y el Reglamento, por la presente notifica a todos los postores que se asegurará afirmativamente de que cualquier contrato celebrado de conformidad con este anuncio, las empresas comerciales desfavorecidas tendrán la oportunidad plena y justa de presentar ofertas en respuesta a esta invitación y no serán discriminadas por motivos de raza, color u origen nacional en consideración a un laudo.</p> <p>La políza del condado de Clark es garantizar que ninguna persona por motivos de raza, color, origen nacional o sexo según lo dispuesto en el Title VI of the Civil Rights Act de 1964, según enmendada, sea excluida por participar en, ser negado los beneficios de, o ser discriminado por cualquier programa o actividad patrocinada por el condado. Para preguntas relacionadas con el programa de Title VI de Obras Públicas del condado de Clark, o para servicios de interpretación o traducción para personas que no hablan inglés. O para que los materiales estén disponibles en un formato alternativo, comuníquese con el coordinador del Title VI de Obras Públicas del condado de Clark por correo electrónico a CCPW-TitleVI@clark.wa.gov o por teléfono a 564-397-4944. Las personas con problemas de audición / habla pueden llamar a Washington Relay Center al 711.</p> <p>For questions regarding Clark County Public Works’ Title VI Program, or for interpretation or translation services for non-English speakers, or otherwise making materials available in an alternate format, contact Clark County Public Works’ Title VI Coordinator via email at CCPW-TitleVI@clark.wa.gov or phone at 564-397-4944. Hearing/speech impaired may call the Washington Relay Center at 711.</p>

Request for Proposal #893

Lacamas Regional Park Access Road Bridge Replacement

<p>6. Timeline for Selection</p>	<p>The following dates are the intended timeline:</p> <table border="1" data-bbox="423 247 1513 747"> <tr> <td>Deadline for Questions and Answers</td> <td>May 23, 2024 by 5:00 pm</td> </tr> <tr> <td>Final date for Addendum, if needed</td> <td>May 24, 2024</td> </tr> <tr> <td>Proposals Dues</td> <td>June 5, 2024</td> </tr> <tr> <td>Proposal Review/Evaluation Period</td> <td>June 5 – 11, 2024</td> </tr> <tr> <td>Interviews</td> <td>June 14, 2024</td> </tr> <tr> <td>Selection Committee Recommendation</td> <td>June 18, 2024</td> </tr> <tr> <td>Contract Negotiation/Execution</td> <td>June 18 – 30, 2024</td> </tr> <tr> <td>Contract Intended to Begin</td> <td>July 1, 2024</td> </tr> </table>	Deadline for Questions and Answers	May 23, 2024 by 5:00 pm	Final date for Addendum, if needed	May 24, 2024	Proposals Dues	June 5, 2024	Proposal Review/Evaluation Period	June 5 – 11, 2024	Interviews	June 14, 2024	Selection Committee Recommendation	June 18, 2024	Contract Negotiation/Execution	June 18 – 30, 2024	Contract Intended to Begin	July 1, 2024
Deadline for Questions and Answers	May 23, 2024 by 5:00 pm																
Final date for Addendum, if needed	May 24, 2024																
Proposals Dues	June 5, 2024																
Proposal Review/Evaluation Period	June 5 – 11, 2024																
Interviews	June 14, 2024																
Selection Committee Recommendation	June 18, 2024																
Contract Negotiation/Execution	June 18 – 30, 2024																
Contract Intended to Begin	July 1, 2024																
<p>7. Employment Verification</p>	<p>The Proposer, if awarded the Contract, shall register and enter into a Memorandum of Understanding (MOU) with the Department of Homeland Security E-Verify program before execution of the Contract. The Contractor shall ensure all Contractor employees and any sub-contractor(s) assigned to perform work under this Agreement are eligible to work in the United States. The Contractor shall provide verification of compliance upon County request. Failure by Contractor to comply with this subsection shall be considered a material breach. (Sole Proprietors must submit a letter stating such.)</p>																
<p>Section IB</p>	<p>Work Requirements</p>																
<p>1. Required Services</p>	<p>See Scope of Work in Section 1A.</p>																
<p>2. County Performed Work</p>	<p>The County will review and provide comments and/or approvals on all work deliverables before finalized. The County will rely on Consultant for final project quality assurance and quality control. During construction, the County will provide construction inspection and management, that will be supported by the Consultant. The County will conduct all public outreach regarding this project. The County will assign a project manager and an environmental permit coordinator to lead this project team.</p>																
<p>3. Deliverables & Schedule</p>	<p>The County would like to complete permitting and design so that the bridge replacement could be completed during the in-water work window of summer 2025.</p>																
<p>4. Place of Performance</p>	<p>Contract performance may take place in the County's facility, the Proposer's facility, a third-party location or any combination thereof.</p>																

Request for Proposal #893

Lacamas Regional Park Access Road Bridge Replacement

<p>5. Period of Performance</p>	<p>A contract awarded as a result of this RFP will be for two (2) years and five (5) months and is intended to begin on July 1, 2024 and end December 31, 2026.</p> <p>Cost for additional option year(s) shall be reviewed prior to extension of the contract.</p> <p>The county also reserves the right to terminate the contract, with thirty (30) days written notice, at any time if the requirements of the contract are not being met satisfactorily, solely in the county's judgment.</p> <p>Clark County reserves the right to extend the contract resulting from this RFP to expend remaining funds for a period of two (2) additional years, in one (1) year increments, with the same terms and conditions, by service of a written notice of its intention to do so prior to the contract termination date.</p>
<p>6. Prevailing Wage Applicable to all public work as defined in RCW 39.04.010(4) Public Works Definition</p>	<p>Pursuant to Washington State RCW 39.12 PREVAILING WAGES ON PUBLIC WORKS all work identified in this project as a public work requires the contractor to pay Washington State prevailing wages and file all affidavits of intent to pay with the WA State Dept of Labor & Industries.</p> <p>Contractors shall meet the requirements for Prevailing Wage and public works requirements, per RCW 39.04.350 BIDDER RESPONSIBILITY CRITERIA – SWORN STATEMENT – SUPPLEMENTAL CRITERIA.</p> <p>For this project select the Clark County rates that apply on the proposal closing date from either of these sites:</p> <p>http://www.wsdot.wa.gov/Design/ProjectDev/WageRates/default.htm http://www.ini.wa.gov/TradesLicensing/PrevWage/WageRates</p> <p>Before payment is made by the Local Agency of any sums due under this contract, the Local Agency must receive from the Contractor and each Subcontractor a copy of "Statement of Intent to Pay Prevailing Wages" (Form L & I Number 700-29) approved by the Washington State Department of Labor and Industries.</p> <p>A fee of \$45.00 per each "Statement of Intent to Pay Prevailing Wages" and "Affidavit of Wages Paid" is required to accompany each form submitted to this Department of Labor and Industries. The Contractor is responsible for payment of these fees and shall make all applications directly to the Department of Labor and Industries. These fees shall be incidental to all the proposed items of this contract.</p>
<p>7. Debarred/Suspended</p>	<p>Federally or Washington State debarred or suspended suppliers may not participate in this Request for Proposal.</p> <p>All proposer's must fill out, sign and submit the "Certification Regarding Debarment, Suspension, and Other Responsibility Matters" form with their proposal to be eligible to participate.</p>
<p>8. Americans with Disabilities Act (ADA) Information</p>	<p>Clark County in accordance with Section 504 of the Rehabilitation Act (Section 504) and the Americans with Disabilities Act (ADA), commits to nondiscrimination on the basis of disability, in all of its programs and activities. This material can be made available in an alternate format by emailing ADA@clark.wa.gov or by calling 564-397-2322.</p>

**Request for Proposal #893
Lacamas Regional Park Access Road Bridge Replacement**

<p>9. Public Disclosure</p>	<p>This procurement is subject to the Washington Public Records Act (the "Act"), chapter 42.56 RCW. Once in the County's possession, all of the RFP Submittals shall be considered public records and available for public records inspection and copying, unless exempt under the Act.</p> <p>If a Respondent or Proposer considers any portion of an RFP Submittal to be protected under the law, whether in electronic or hard copy form, the Respondent or Proposer shall clearly identify each such portion with the word "PROPRIETARY". The County will notify the Respondent or Proposer in writing of the request and allow the Respondent or Proposer ten (10) days to obtain a court order enjoining release of the record(s). If the Respondent or Proposer does not take such action within the ten (10) day period, the County will release the portions of the RFP Submittal deemed subject to disclosure. All Respondents and Proposers who provide RFP Submittals for this procurement accept the procedures described above and agree that the County shall not be responsible or liable in any way for any losses that the party may incur from the disclosure of records to a third party who requests them.</p>
<p>10. Insurance/Bond</p>	<p>A. <u>Waiver of Subrogation</u> All insurance coverage maintained or procured pursuant to this agreement shall be endorsed to waive subrogation against County, its elected or appointed officers, agents, officials, employees and volunteers or shall specifically allow Contractor or others providing insurance evidence in compliance with these specifications to waive their right of subrogation prior to a loss. Contractor hereby waives its own right of subrogation against County and shall require similar written express waivers and insurance clauses from each of its subcontractors.</p> <p>B. <u>Proof of Insurance</u> Proof of Insurance shall be provided prior to the starting of the contract performance. Proof will be on an ACORD Certificate(s) of Liability Insurance, which the Proposer shall provide to Clark County. Each certificate will show the coverage, deductible and policy period. Policies shall be endorsed to state that coverage will not be suspended, voided, canceled or reduced without a 30-day written notice by mail to the County. It is the Proposer's responsibility to provide evidence of continuing coverage during the overlap periods of the policy and the contract.</p> <p>C. <u>Worker's Compensation</u> As required by the industrial insurance laws of the State of Washington.</p> <p>D. <u>Automobile</u> If the Proposer or its employees use motor vehicles in conducting activities under this Contract, liability insurance covering bodily injury and property damage shall be provided by the Proposer through a commercial automobile insurance policy. The policy shall cover all owned and non-owned vehicles. Such insurance shall have minimum limits of \$1,000,000 per occurrence, combined single limit for bodily injury liability and property damage liability with a \$1,000,000 annual aggregate limit. If the Proposer does not use motor vehicles in conducting activities under this Contract, then written confirmation to that effect on Proposer letterhead shall be submitted by the Proposer.</p> <p>E. <u>Commercial General Liability (CGL) Insurance</u> Written under ISO Form CG0001 or its latest equivalent with minimum limits of \$2,000,000 per occurrence and in the aggregate for each one-year policy period. Personal and Advertising Injury \$1,000,000 and General Aggregate \$1,000,000. This policy must renew annually. This coverage may be any combination of primary, umbrella or excess liability coverage affording total liability limits of not less than \$1,000,000 per occurrence and in the aggregate. However, if other policies are added they must be a follow-form policy in language, renewal date, and have no more exclusions than the underlying coverage. Products and Completed Operations coverage shall be provided for a period of three years following Substantial Completion of the</p>

**Request for Proposal #893
Lacamas Regional Park Access Road Bridge Replacement**

	<p>Work. The deductible will not be more than \$50,000 unless prior arrangements are made with Clark County on a case-by-case basis; the criterion is the Contractor's liquidity and ability to pay from its own resources regardless of coverage status due to cancellation, reservation of rights, or other no-coverage-enforce reason. Coverage shall not contain any endorsement(s) excluding nor limiting Product/Completed Operations, Contractual Liability or Cross Liability. Clark County needs to be listed as additional insured.</p> <p><u>F. Professional Liability (aka Errors and Omissions)</u> The Proposer shall obtain, at Proposer's expense, and keep in force during the term of this contract Professional Liability insurance policy to protect against legal liability arising out of contract activity. Such insurance shall provide a minimum of \$1,000,000 per occurrence. The deductible will not be more than \$25,000 unless prior arrangements are made with Clark County on a case-by-case basis; the criterion is the Proposer's liquidity and ability to pay from its own resources. It should be an "Occurrence Form" policy. If the policy is "Claims Made", then Extended Reporting Period Coverage (Tail coverage) shall be purchased for three (3) years after the end of the contract.</p> <p><u>G. Umbrella Liability Coverage</u> Umbrella Coverage in the amount of \$1,000,000 shall be provided and will apply over all liability policies without exception, including Commercial General Liability and Automobile Liability.</p> <p><u>H. Additional Insured</u> Clark County, its officers, employees and agents, will be named on all policies of contractor and any subcontractors as an additional insured, with no restrictions or limitations concerning products and completed operations. This coverage shall be primary coverage and noncontributory to any coverage maintained by Clark County. The contractor shall provide Clark County with verification of insurance and endorsements required by this agreement. Clark County reserves the right to require complete, certified copies of all required insurance policies at any time. All insurance shall be obtained from an insurance company authorized to do business in the State of Washington.</p> <p>All policies must have a Best's Rating of A-VII or better.</p>
<p>11. Plan Holders List</p>	<p>All proposers are required to be listed on the plan holders list.</p> <ul style="list-style-type: none"> ✓ Prior to submission of proposal, confirm your organization is on the Plan Holders List below: <p>To view the Plan Holders List, click on the link below or copy and paste into your browser. Clark County RFP site: https://clark.wa.gov/internal-services/purchasing-overview</p> <ul style="list-style-type: none"> • If your organization is NOT listed, submit Attachment B - Letter of Interest to ensure your inclusion. • Proposals received by Clark County by proposers not included on the Plan Holders List may be considered non-responsive.

**Request for Proposal #893
Lacamas Regional Park Access Road Bridge Replacement**

Part II Proposal Preparation and Submittal

Section IIA	Pre-Submittal Meeting / Clarification
1. Pre-Submittal Meeting	<p>There are no plans to hold a pre-submittal meeting.</p> <p>Consultants are encouraged to visit Lacamas Regional Park to view the bridge.</p>
2. Proposal Clarification	<p>Questions and Requests for Clarification regarding this Request for Proposal must be directed in writing, via email, to the person listed on the cover page.</p> <p>The deadline for submitting such questions/clarifications is May 23, 2024 by 5:00 pm.</p> <p>An addendum will be issued no later than May 24, 2024 to all recorded holders of the RFP if a substantive clarification is in order.</p> <p>The Questions & Answers/Clarifications are available for review at the link below. Each proposer is strongly encouraged to review this document prior to submitting their proposal.</p> <p>Clark County RFP site: https://clark.wa.gov/internal-services/request-proposal-1</p>
Section IIB	Proposal Submission
1. Proposals Due	<p>Sealed proposals must be received no later than the date, time and location specified on the cover of this document.</p> <p>The outside of the envelope/package shall clearly identify:</p> <ol style="list-style-type: none"> 1. RFP Number and; 2. TITLE and; 3. Name and Address of the Proposer. <p>Responses received after submittal time will not be considered and will be returned to the Proposer - unopened.</p> <p>Proposals received with insufficient copies (as noted on the cover of this document) cannot be properly disseminated to the Review Committee and other reviewers for necessary action, therefore, may not be accepted.</p>
2. Proposal	<p>Proposals must be clear, succinct and not exceed ten (10) pages, excluding resumes, coversheet and debarment form. Proposer's who submit more than the pages indicated may not have the additional pages of the proposal read or considered.</p> <p>For purposes of review and in the interest of the County, the County encourages the use of submittal materials (i.e. paper, dividers, binders, brochures, etc.) that contain post-consumer recycled content and are <u>readily recyclable</u>.</p> <p>The County discourages the use of materials that cannot be readily recycled such as PVC (vinyl) binders, spiral bindings, and plastic or glossy covers or dividers. Alternative bindings such as</p>

Request for Proposal #893
Lacamas Regional Park Access Road Bridge Replacement

	<p>reusable/recyclable binding posts, reusable binder clips or binder rings, and recyclable cardboard/paperboard binders are examples of preferable submittal materials.</p> <p>Proposers are encouraged to print/copy on both sides of a single sheet of paper wherever applicable; if sheets are printed on both sides, it is considered to be two pages. Color is acceptable, but content should not be lost by black-and-white printing or copying.</p> <p>All submittals will be evaluated on the completeness and quality of the content. Only those Proposers providing complete information as required will be considered for evaluation. The ability to follow these instructions demonstrates attention to detail.</p> <p>Additional support documents, such as sales brochures, should not be included with each copy unless otherwise specified.</p>
<p>Section IIC</p>	<p>Proposal Content</p>
<p>1. Cover Sheet</p>	<p>This form is to be used as your proposal Cover Sheet. See Cover Sheet - Attachment A.</p>
<p>2. Project Team</p>	<p>Identify the prime and sub-consultants and how the team will work together to deliver on this project.</p>
<p>3. Management Approach</p>	<p>Identify the proposed project manager and key personnel of the project team including the relevant experience, qualifications and project roles of each member. For each member, describe their experience as relevant to this project.</p>
<p>4. Respondent's Capabilities</p>	<p>At least three (3) client references for similar bridge repair or replacement projects led by the proposed project manager within the last seven years. Please include the full name of the client, phone number and email.</p>
<p>5. Project Approach and Understanding</p>	<p>Please provide the following information for no more than five relevant projects with similar scope and size that have been completed or are currently being led by members of the consultant design team.</p> <ol style="list-style-type: none"> 1. Name of project 2. Project website, if applicable 3. Brief project description highlighting special attributes/features of the project 4. Project design team 5. Project budget and actual cost, if applicable <p>All costs for developing submittals in response to this RFQ are the obligation of the consultant and are not chargeable to the county. All submittals will become property of the county and will not be returned. Submittals may be withdrawn at any time prior to the published close date, provided notification is made in writing.</p>
<p>6. Proposed Cost</p>	<p>Proposals will be scored on qualifications only; cost should not be included.</p>

Request for Proposal #893
Lacamas Regional Park Access Road Bridge Replacement

Part III Proposal Evaluation & Contract Award

Section IIIA	Proposal Review and Selection														
1. Evaluation and Selection:	The county intends to enter into an agreement with the consultant who provides a proposal that, in the opinion of the county, best meets all the evaluation criteria listed below (receives the highest score), as determined by the county's selection committee. Selected firms may be invited to participate in an interview.														
2. Evaluation Criteria Scoring	<p>Each proposal received in response to the RFP will be objectively evaluated and rated according to a specified point system.</p> <p>A one hundred (100) point system will be used, weighted against the following criteria:</p> <table border="1" data-bbox="399 716 1422 1213"> <tr> <td>Demonstrated excellence in design, specifications, and budgeting and understanding of bridge engineering</td> <td>25</td> </tr> <tr> <td>Qualifications of key personnel and project team</td> <td>25</td> </tr> <tr> <td>Demonstrated experience with environmental permitting and construction support for bridge repair projects</td> <td>20</td> </tr> <tr> <td>Experience with projects of similar scale and scope</td> <td>15</td> </tr> <tr> <td>References</td> <td>10</td> </tr> <tr> <td>Overall quality of content</td> <td>5</td> </tr> <tr> <td style="text-align: right;">Total Points</td> <td>100</td> </tr> </table>	Demonstrated excellence in design, specifications, and budgeting and understanding of bridge engineering	25	Qualifications of key personnel and project team	25	Demonstrated experience with environmental permitting and construction support for bridge repair projects	20	Experience with projects of similar scale and scope	15	References	10	Overall quality of content	5	Total Points	100
Demonstrated excellence in design, specifications, and budgeting and understanding of bridge engineering	25														
Qualifications of key personnel and project team	25														
Demonstrated experience with environmental permitting and construction support for bridge repair projects	20														
Experience with projects of similar scale and scope	15														
References	10														
Overall quality of content	5														
Total Points	100														
Section IIIB	Contract Award														
1. Consultant Selection	<p>The County will determine the most qualified proposer based on the evaluation criteria listed using predetermined weights, the attributes of the Proposers and the overall responsiveness of the Proposal. If the County does not reach a favorable agreement with the top Proposer, the County shall terminate negotiations and begin negotiations with the next qualified Proposer. If the County is unable to reach agreeable terms with either Proposer, they may opt to void the RFP and determine next steps.</p> <p>Clark County reserves the right to accept or reject any or all proposals received, to negotiate with any or all prospective contractors on modifications to proposals, to waive formalities, to postpone award, or to cancel in part or in its entirety this RFP. Clark County reserves the right to award the contract based on the best interests of the County.</p>														
2. Contract Development	<p>The proposal and all responses provided by the successful Proposer may become a part of the final contract.</p> <p>Upon selection of a consultant, the county intends to enter into an agreement with the consultant using our standard Professional Services Agreement (see Attachment I).</p>														

Request for Proposal #893
Lacamas Regional Park Access Road Bridge Replacement

3. Award Review	The public may view Request for Proposal documents by submitting a public records request at www.clark.wa.gov .
4. Orientation/Kick-off Meeting	A project kick-off meeting will be held two weeks after the contract has been fully executed.

**Request for Proposal #893
Lacamas Regional Park Access Road Bridge Replacement**

Attachment A: COVER SHEET

General Information:

Legal Name of Proposing Firm	
Street Address	
City State Zip Code	
Contact Person Title	
Phone	
Program Location (if different than above)	
Email Address	
Tax Identification Number	

ADDENDUM:

Proposer shall acknowledge receipt of Addenda by checking the appropriate box(es).

None 1 2 3 4 5 6

NOTE: Failure to do so, shall render the proposer non-responsive and therefore be rejected.

I certify that to the best of my knowledge the information contained in this proposal is accurate and complete and that I have the legal authority to commit this agency to a contractual agreement. I realize the final funding for any service is based upon funding levels, and the approval of the Clark County Council and required approvals.

Authorized Signature of Proposing Firm

Date

Printed Name

Title

**Request for Proposal #893
Lacamas Regional Park Access Road Bridge Replacement**

Attachment B: LETTER OF INTEREST

Legal Name of Proposing Firm	
Street Address	
City State Zip Code	
Contact Person Title	
Phone	
Program Location (if different than above)	
Email Address	

- All proposers are required to be included on the plan holders list.
- If your organization is NOT listed, submit the ‘Letter of Interest’ to ensure your inclusion.

Email Letter of Interest to: Koni.Odell@clark.wa.gov and Priscilla.Mason@clark.wa.gov

Clark County web link: <https://clark.wa.gov/internal-services/request-proposal-1>

This document will only be used to add a proposer to the plan holders list. Submitting this document does not commit proposer to provide services to Clark County, nor is it required to be submitted with proposal.

Proposals may be considered non-responsive if the Proposer is not listed on the plan holders list.

**Request for Proposal #893
Lacamas Regional Park Access Road Bridge Replacement**

Attachment C



Clark County, Washington

**Certification Regarding
Debarment, Suspension and Other Responsibility Matters**

The prospective participant certifies to the best of its knowledge and belief that it and its principals:

- (a) Are not presently debarred, suspended, proposed for debarment, declared ineligible, or voluntarily excluded from covered transactions by any Federal, State or local department or agency;
- (b) Have not within a three-year period preceding this proposal been convicted of or had a civil judgment rendered against them for commission of fraud or a criminal offense in connection with obtaining, attempting to obtain, or performing a public (Federal, State, or local) transaction or contract under a public transaction; violation of Federal or State antitrust statutes or commission of embezzlement, theft, forgery, bribery, falsification or destruction of records, making false statements, or receiving stolen property;
- (c) Are not presently indicted for or otherwise criminally or civilly charged by a government entity (Federal, State, or local) with commission of any of the offenses enumerated in paragraph (1)(b) of this certification; and
- (d) Have not within a three-year period preceding this application/proposal had one or more public transactions (Federal, State, or local) terminated for cause or default.

I understand that a false statement on this certification may be grounds for rejection of this proposal or termination of the award. In addition, under 18 USC Sec. 1001, a false statement may result in a fine of up to \$10,000 or imprisonment for up to 5 years, or both.

Company Name

Typed Name & Title of Authorized Representative

Signature of Authorized Representative

Date

I am unable to certify to the above statements. My explanation is attached.



Lacamas Regional Park Bridge Location

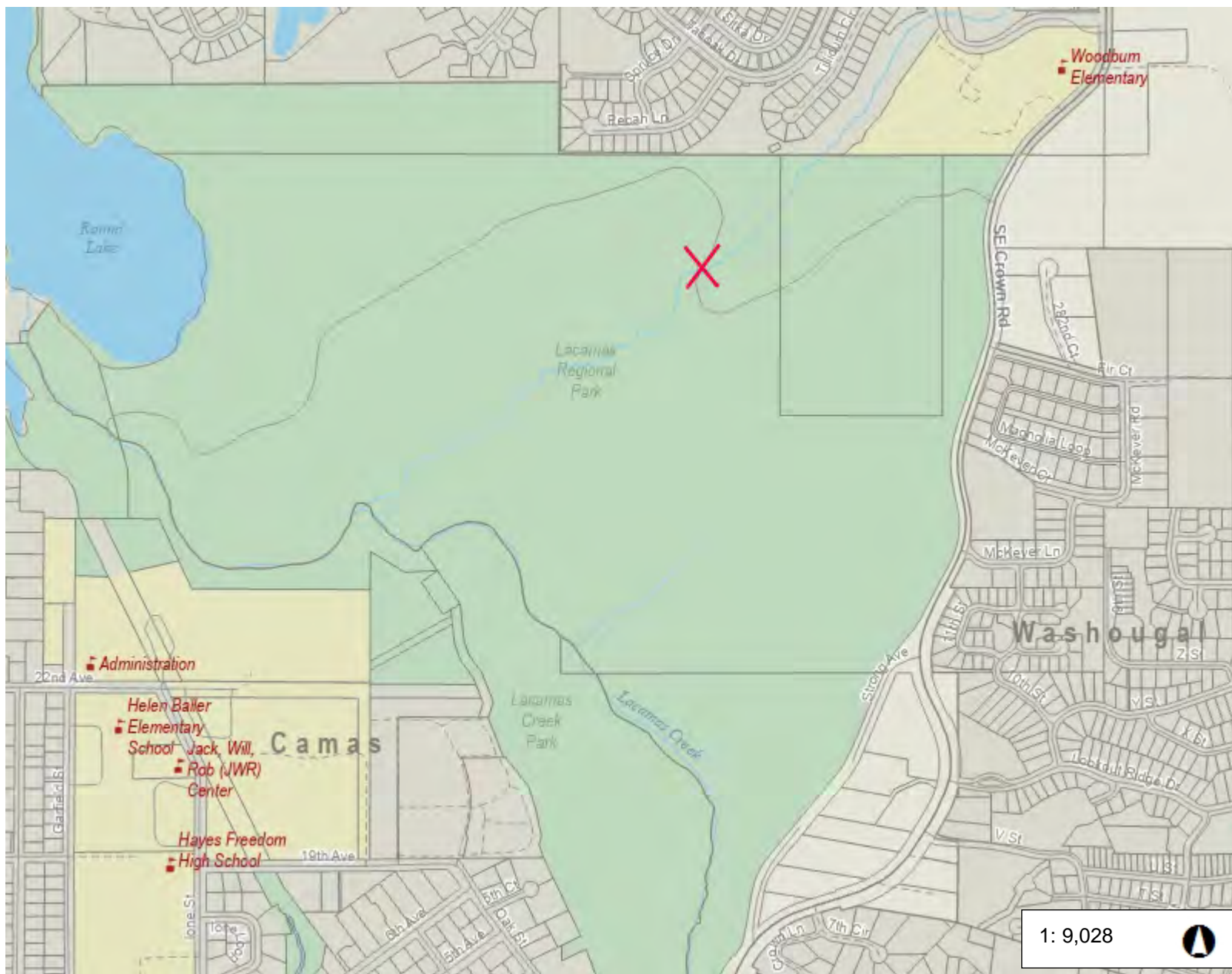

Legend

□ Taxlots

Notes:

Bridge location is marked with red "X"

1: 9,028



1,504.7 0 752.33 1,504.7 Feet

WGS_1984_Web_Mercator_Auxiliary_Sphere
Clark County, WA. GIS - <http://gis.clark.wa.gov>

This map was generated by Clark County's "MapsOnline" website. Clark County does not warrant the accuracy, reliability or timeliness of any information on this map, and shall not be held liable for losses caused by using this information. Taxlot (i.e., parcel) boundaries cannot be used to determine the location of property lines on the ground.



Date: June 28, 2023 **File:** _____
To: Clark County
From: Ian Cannon, PE; Heidi Clayville, PE ; Vahid Eghbalifarkoosh
Project: Lacamas Creek Bridge
Subject: Inspection Report

INSPECTION REPORT

Introduction

The Lacamas Creek Bridge is built of two re-used railcars, in parallel, from the early 1900s. The bridge is a single span, 41.5 feet long overall and approximately 20 feet wide. The bridge consists of four main built-up steel girders as well as 4 channels (running in longitudinal direction), with seven steel diaphragms (running in transverse direction), timber spacers on top of the steel elements (running in longitudinal and transverse directions), and a timber deck (transverse). At the abutments, diaphragms sit on steel blocks supported on the concrete pier cap. A team from Exeltech inspected the bridge on April 6, 2023. During the inspection of the bridge, we observed substantial corrosion and rust on the steel elements of the bridge (i.e. girders, diaphragms, connection elements, etc.), and some rotting and deterioration of the timber deck as well as water ponding on the deck. In addition, the banks appear susceptible to scour.

Bridge Layout

The following figures illustrate the layout of the bridge and its major elements:

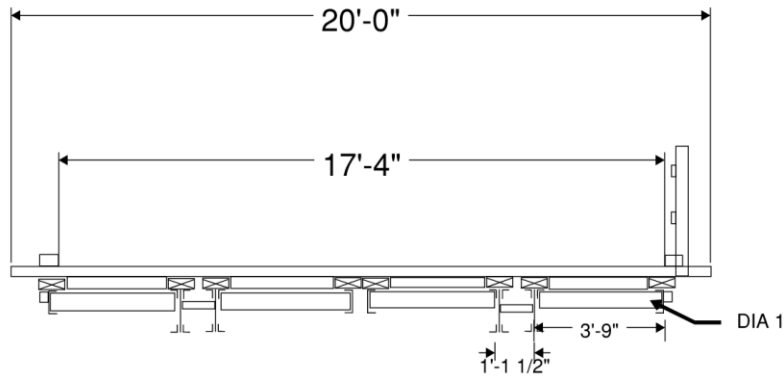

Cross Section of the Bridge

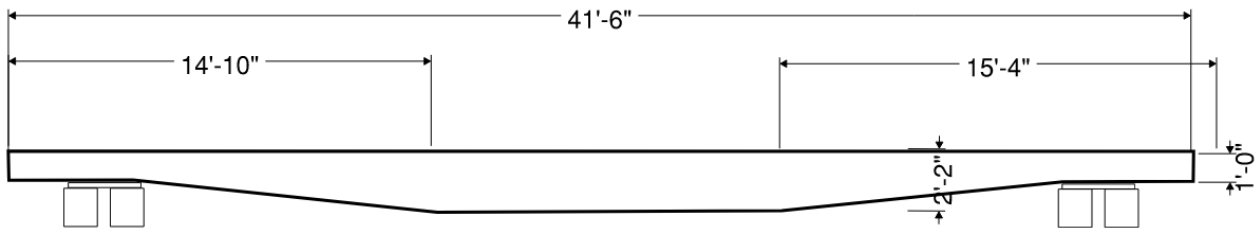

Girder Elevation View

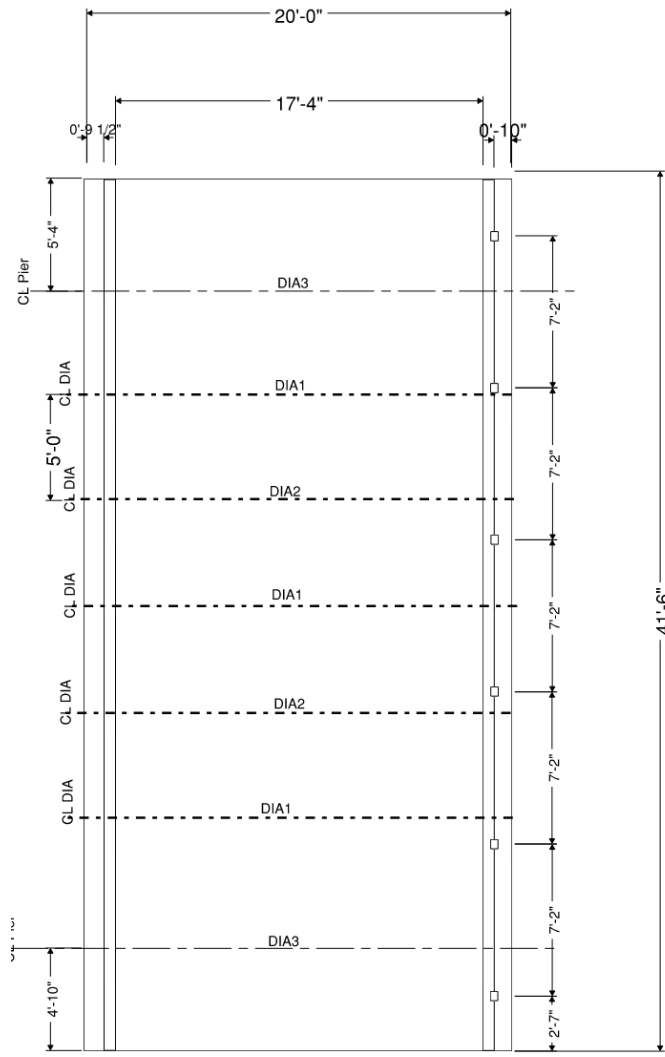

Plan View of the Bridge

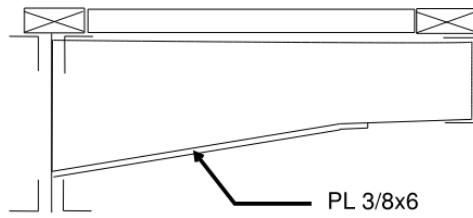

Elevation of Diaphragm Type 2

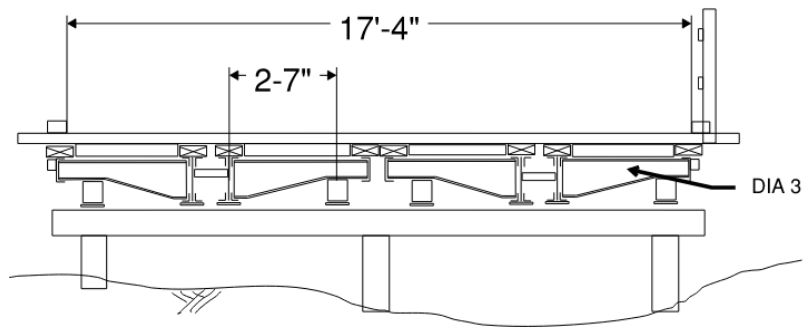

Typical Bent Elevation

The element dimensions are as follows:

Deck: 3.625"X12" Sawn Lumber, Timber Spacer: 6"X12 Sawn Lumber, Curb: 6"X6" Sawn Lumber, Railing Posts: 3.5"X5.5", Rails: 1.5"X5.5", Railing Spacing: 7'-2"

Girders: C Channels with $d=8.25"$, $tw=3/8"$, $b=2\ 5/8"$, $tf=5/16"$, Built-Up Girders: Web= PL3/8"X12" and PL3/8"X26", Flanges=L3 1/2"X3 1/2"X5/16"

Diaphragms with typical spacing of 5'-0":

DIA1-C Bent Plate (constant depth): $d=7.5"$, $tw=1/4"$, $b=3"$, $tf=1/4"$

DIA2-C Bent Plate (varying depth): $d=7.5"-12"$, $tw=1/4"$, $b=6"$, $tf=1/4"$, cover plate: PL 3/8"x6"

DIA3- Double C Bent Plate (End Dia varying depth): $d=7.5"-12"$, $tw=1/4"$, $b=6"$, $tf=1/4"$, cover plate: PL 3/8"x6"

Bearings are 9"x14" steel block.

d – depth (height) of member

tw – thickness of web

tf – thickness of flange

b – width of flange

Bridge Inspection Photos

As stated earlier, Exeltech Team visited the Lacamas Creek Bridge on April 2023. In this section, photos from the April 2023 inspection are presented which include the longitudinal and transverse elements, timber deck, and connections:



Photo shows significant rust on the steel girders as well as buckling of the plate between girders (looking south)



Photo shows significant rust on the steel girders as well as steel diaphragms



Photo shows significant rust on the steel connection elements, girders as well as steel diaphragms



Photo shows significant rust on the steel connection elements, girders as well as steel diaphragms



Photo shows significant rust on the steel connection elements, girders as well as steel diaphragms



Photo shows significant rust on the steel girders



Photo shows significant rust on the steel connection elements, girders as well as steel diaphragms



Photo shows significant rust on the steel girders



Photo shows significant rust on the steel connection elements, diaphragm support blocks, and steel diaphragms



Longitudinal photo from under the bridge shows rust on the steel girders and steel diaphragms. Erosion of stream bank is also shown.



Photo shows significant rust on the steel connection elements, girders and steel diaphragms



Photo shows vegetation and moss growth on pier cap beams



Photo taken at the abutment shows significant rust on the steel connection elements, girders, diaphragm support blocks, and steel diaphragms



Photo taken at the abutment shows significant rust on the steel connection elements, steel diaphragms and diaphragm support blocks over pier cap



Photo taken at abutment shows significant rust on the steel connection elements, steel diaphragms, and supporting diaphragm blocks over pier cap



Photo taken at abutment shows significant rust on the steel connection elements, and girders



Photo shows significant rust on the steel connection elements, girders and steel diaphragms



Photo shows significant rust on the steel connection elements, girders and steel diaphragms



Photo shows significant rust on the steel element



Photo shows significant rust on the steel connection elements, girders and steel diaphragms



Photo shows significant rust on the steel connection elements, girders, and steel diaphragms

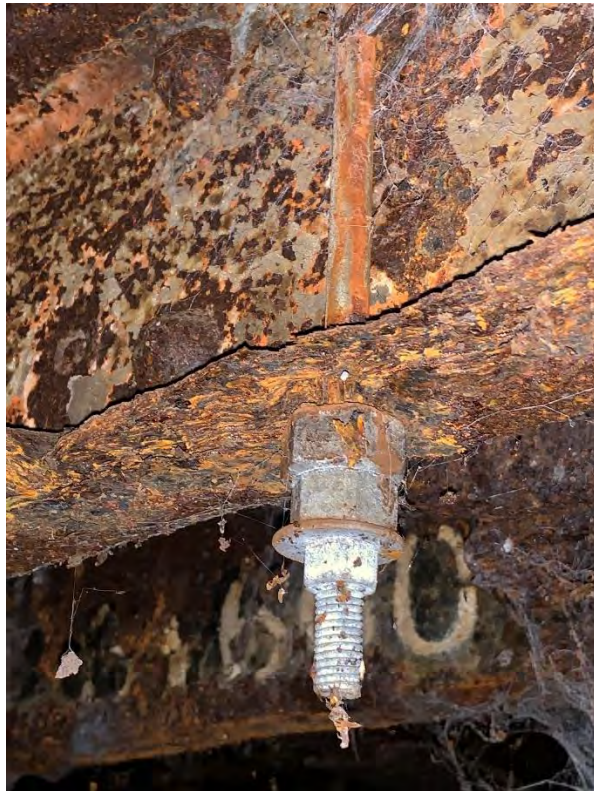

Photo shows significant rust on the steel girder, and rust on the connector rod and bolted connection elements



Photo shows significant rust on the steel connection elements, girders, and steel diaphragms



Photo shows buckling of the plate between girders, significant rust on the steel connection elements, girders, and as steel diaphragms



Photo shows significant rust on the steel girders



Photo shows significant rust on the steel connection elements

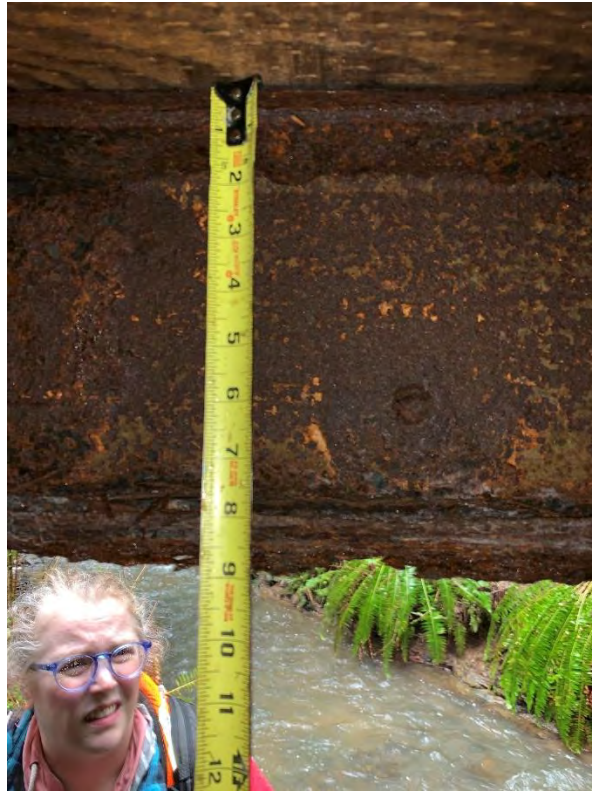

Photo shows significant rust on the steel girder



Photo shows significant rust on the steel girder (web and flanges)



Photo shows significant rust on the steel girder (web and flanges)



Photo shows railing and its bolted connection



Photo shows the steel base of railing



Photo shows deterioration of the timber deck as well water ponding on the deck



Photo shows the support diaphragm block



Date: July 6, 2023 **File:** _____
To: Clark County _____
From: Ian Cannon, PE; Heidi Clayville, PE ; Vahid Eghbalifarkoosh _____
Project: Lacamas Creek Bridge _____
Subject: Technical Memo _____

TECHNICAL MEMO

Introduction

The Lacamas Creek Bridge is built out of two re-used railcars in parallel from the early 1900s. The bridge is a single span, 41.5 feet long overall and approximately 20 feet wide. The bridge consists of four main built-up steel girders as well as 4 channels (running in longitudinal direction), with seven steel diaphragms (running in transverse direction), timber spacers on top of the steel elements (running in longitudinal and transverse directions), and a timber deck (transverse). At the abutments, diaphragms sit on steel blocks supported on the concrete pier cap. A team from Exeltech inspected the bridge on April 6, 2023. During the inspection we observed substantial corrosion and rust on the steel elements of the bridge including girders, diaphragms, connection elements (plates, rivets, rods), and support diaphragm blocks. The timber deck has shows some rot and water ponding.

Load Rating

Load rating of this bridge was performed for H-20 loading configuration and per WSDOT Bridge Design Manual dated September 2020 and Load and Resistance Factor (LFR) method was used in the load rating. The load rating was conducted using BRASS-GIRDER (Version 8.9), CSI Bridge (Version 24.2.0 Advanced), and Microsoft Excel software. The following material properties were assumed in the load rating:

Steel: Yield strength=30 ksi, Ultimate strength=60 ksi, Elastic modulus=29000 ksi, Unit Weight=490 pcf
 Timber: Bending strength=1.5 ksi, Shear strength=0.18 ksi, Unit Weight=50 pcf

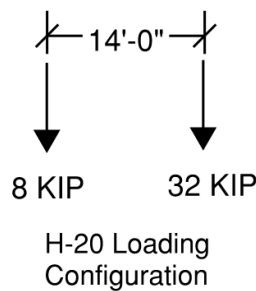

Due to the advanced state of steel corrosion, 50% section loss was assumed for flange elements of the main girders, edge channels, and diaphragm elements.

The controlling element for the load rating was found to be mid-span bending of the main girders.

Based on the load rating, it is found that the maximum capacity of the bridge is 3.6 ton two axle vehicle. 3.6 tons is less than the weight of a fully loaded $\frac{3}{4}$ ton pickup. It is strongly recommended that the county prevent any vehicle heavier than 3.6 tons from using the bridge.

Bridge Layout

The following figures illustrate the layout of the bridge and some of the elements:

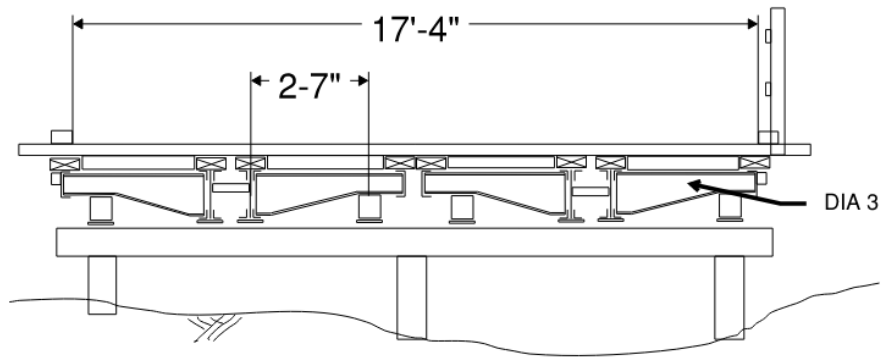

Typical Bent Elevation

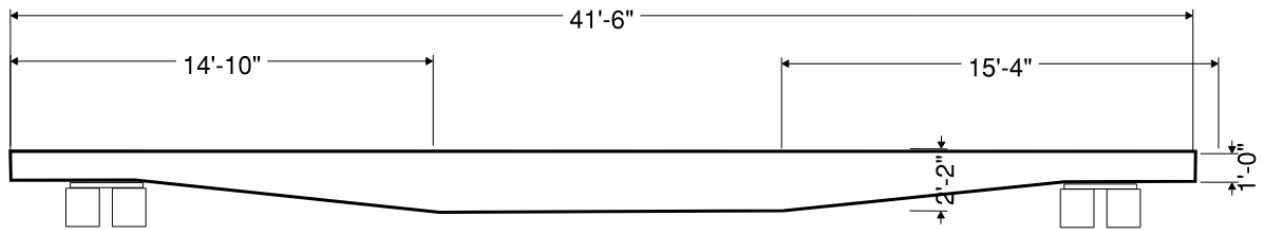

Girder Elevation View

Representative Bridge Inspection Photos

As stated earlier, Exeltech Team visited the Lacamas Creek Bridge on April 2023. The following photos illustrate some of the representative photos in which significant rust and deterioration of the structural elements are visible:



Representative photos illustrating significant rust on the steel girders, diaphragms, connection elements, and buckling of the plate between girders



EXPIRES: 1/14/ 2025

Date: January 14, 2024 **File:** _____

To: Clark County

From: Ian Cannon, PE; Heidi Clayville, PE ; Vahid Eghbalifarkoosh

Project: Lacamas Creek Bridge

Subject: Replacement and Repair Options

REPLACEMENT AND REPAIR OPTIONS FOR LACAMAS CREEK

Summary

Clark County contracted with Exeltech Consulting Inc to inspect, load rate, and develop replacement alternatives for the Lacamas Creek Bridge. Exeltech investigated repair of the Lacamas bridge as well as two replacement options for this bridge. Due to the poor condition of the existing bridge, rehabilitation is not considered feasible. Two replacement options are presented in this report, one with capacity for all legal loads, and one with capacity for a 5 ton vehicle. Conceptual plans and cost estimates are provided.

Location Map

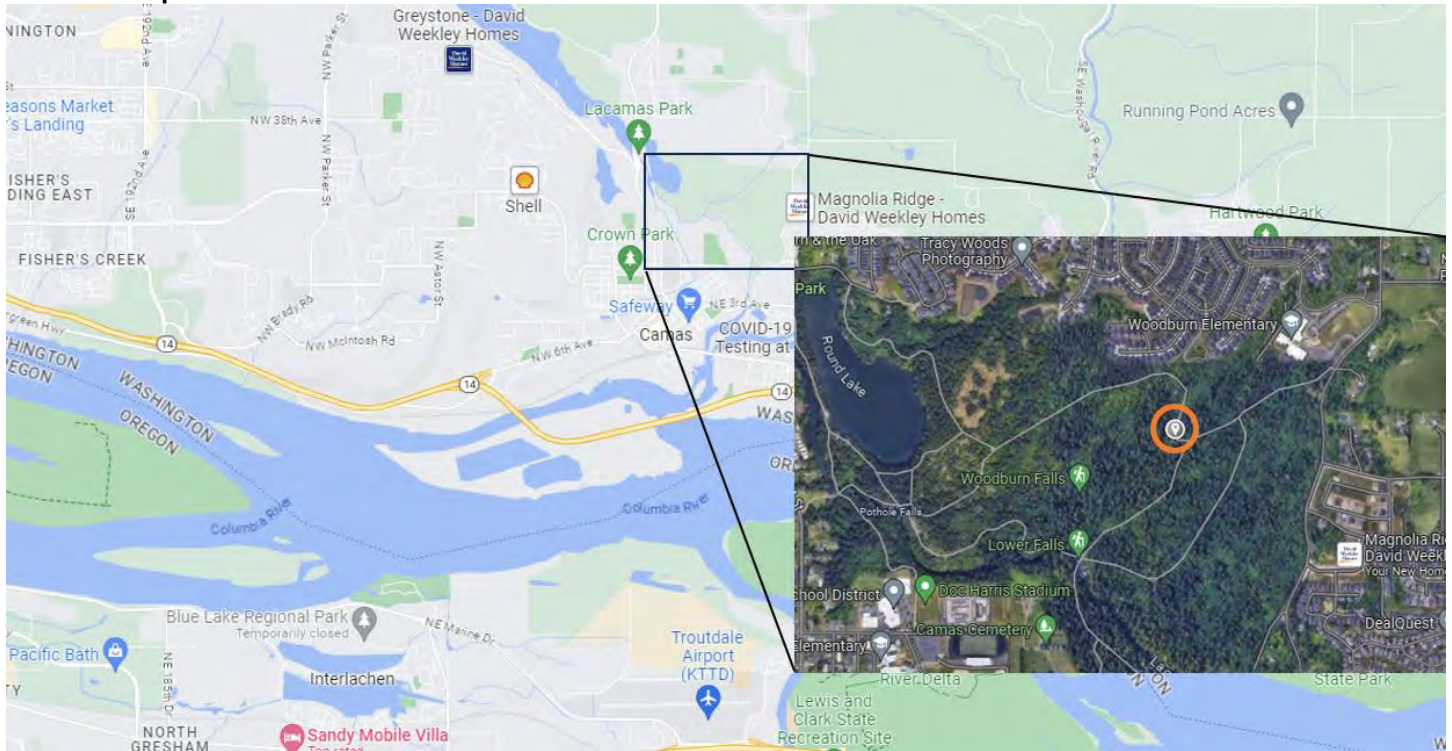

Assumptions

No topographic survey was conducted as part of this study, however Exeltech performed field measurements to obtain the approximate trail profile and channel cross section at the location of the bridge. Quantities and bridge geometry are based on these field measurements. Based on the field measurements, a channel width of 23 feet, and assuming slopes under the bridge of 2 horizontal to 1 vertical, a bridge length of 60 feet was established for the replacement bridge options.

No hydraulic calculations have been performed to determine stream flow characteristics at the site. Based on the field observation conducted by Exeltech, the full width of the channel upstream of the existing bridge was observed to be approximately 23 ft. There appears to be little evidence that the bridge is overtopped. However, replacement alternatives provide 1 additional foot of freeboard when compared with the existing bridge.

No geotechnical borings were performed on the site. The geotechnical conditions were assumed from the Web Soil Survey of US Department of Agriculture. As a result of assuming the presence of clay soil, steel piles were used in the conceptual plans and cost estimates. The piles were assumed to be 60 ft in length.

Additional specific assumptions for each option are provided in the following sections.

Rehabilitation Option

It is not considered feasible to rehabilitate the existing bridge to provide desired service life due to the following:

- Significant corrosion of steel structural members,
- Deteriorated condition of the timber deck,
- Unknown foundation details and conditions, and
- Scour of the channel around the existing abutments indicating that the current hydraulic opening is inadequate.

Replacement Option 1 – Prestressed Precast Concrete Voids Slabs

This option is intended to have capacity for standard vehicular traffic (AASHTO HL-93 loading). This would provide capacity for typical emergency vehicles. This bridge would have deck dimensions of approximately 60ft long and 12ft wide. The anticipated Conceptual plans and cost estimate are provided in Appendix 1. The total cost of this option, including construction, sales tax, preliminary engineering, and construction administration is estimated to be \$770,000.



This option would consist of three 60ft long by 4ft wide by 26in deep precast prestressed concrete voided slabs laid side by side to provide a deck width of 12 feet. These slabs are connected to each other using threaded rods and grouted keyways. Three 12 inch diameter steel piles with a length of 60 feet each are assumed to be needed under each abutment for this option. Slab depth is based on load

tables from Knife River Prestress. The bridge would be provided with a standard pedestrian railing. This is a low maintenance, utilitarian bridge, with limited opportunities for aesthetic treatments. Field construction time is estimated to be three months. Construction timing will need to account for in-water-work periods.

Replacement Option 2 - Prefabricated Steel Truss Bridge

This option is intended to have capacity for a standard pickup truck up to 5 tons (AASHTO H-5 loading). This would provide capacity for typical park maintenance vehicles. This bridge would have deck dimensions of approximately 60ft long and 10ft wide. The anticipated Conceptual plans and cost estimate are provided in Appendix 2. The total cost of this option, including construction, sales tax, preliminary engineering, and construction administration is estimated at \$720,000.



This option would consist of a prefabricated steel truss with a concrete deck. The truss would extend above the deck to about waist height. The truss would sit on cast in place concrete abutments, each supported on two 12in diameter steel piles. This type of structure is relatively low maintenance, although care must be taken to prevent build up of debris on lower chord connections. The bridge could be painted or fabricated from weathering steel. This type of bridge may provide more opportunities for aesthetic treatments. Field construction time is estimated to be three months. Construction timing will need to account for in-water-work periods.

Potential Environmental Permits

The following summarizes the potential environmental permits and authorizations required for the project.

Section 404 Discharge of Dredge and Fill Permit

Assuming the project involves excavation or placement of fill below OHWM of Lacamas Creek, the project will require a Section 404 Permit from USACE. If the project impacts wetlands that meet the federal definition under the Clean Water Act, the Section 404 permit would include those areas as well. The Washington Department of Ecology will also review wetland impacts for wetlands meeting state or federal jurisdiction as part of the Section 404 permit application process.

Section 401 Water Quality Certification

As the project has potential to discharge into Lacamas Creek, a water of the United States, a Section 401 Water Quality Certification will be required from the Washington Department of Ecology.

NPDES Construction Stormwater General Permit

As stormwater from the construction site could discharge into Lacamas Creek, a water of the United States, a NPDES Construction Stormwater General Permit will be required from the Washington Department of Ecology.

HPA

Because this project will occur in or near a water of the state, it will require Hydraulic Project Approval (HPA) from the Washington Department of Fish and Wildlife (WDFW).

SEPA

The project area occurs in an area classified as fish and wildlife habitat, an aquifer recharge area, a flood hazard area, and a geologically hazardous area, all of which are types of critical areas. As such, SEPA documentation will be required. Clark County will be the lead agency for SEPA review and determination.

Wetland and Habitat Permit

As the project will impact aquatic habitats and may impact wetlands, the project will require a Wetland and Habitat Permit from Clark County.

Shoreline Permit and Floodplain Review

The project will impact areas within Shoreline Management Act jurisdiction and will need to be reviewed by the Clark County Shoreline Administrator through the shoreline permitting process. This review will also consider impacts to the floodplain. The work may fall under a Clark County Public Works programmatic exemption (in effect until November 2025) and may additionally be exempt under WAC 173-27-040 (2)(b) – Normal Maintenance and Repair. The Clark County Shoreline Administrator will make this determination.

Grading and Drainage Permit

The project may require a Grading and Drainage Permit from Clark County Community Development.

NEPA

Assuming this project will not receive federal funding, NEPA documentation will not be required. However, USACE is required to ensure the issuance of the Section 404 permit, as a federal action, maintains NEPA compliance. Supplemental information that may be required by the USACE typically relates to cultural resources and fish and wildlife information, frequently already available in County records and critical areas reports prepared for wetland and habitat permits.

Appendix 1
Replacement Option 1 – Prestressed Precast Concrete Voided Slabs
Conceptual Plan and Cost Estimate

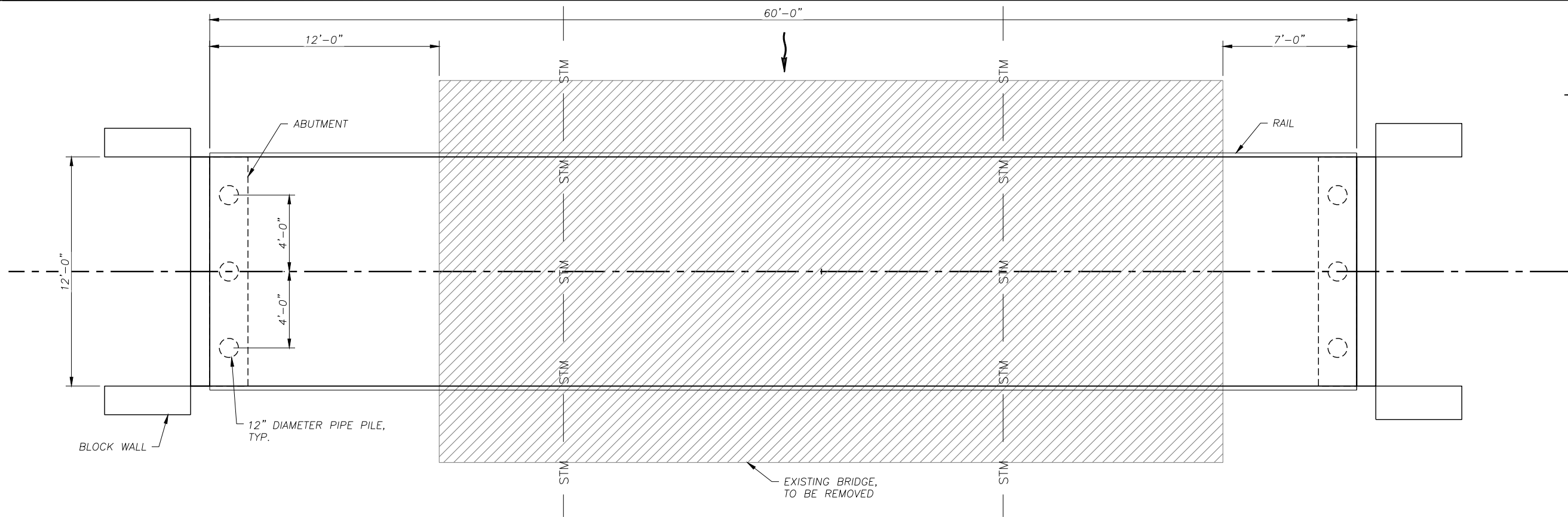

PLAN
SCALE: 1"=3'-0"

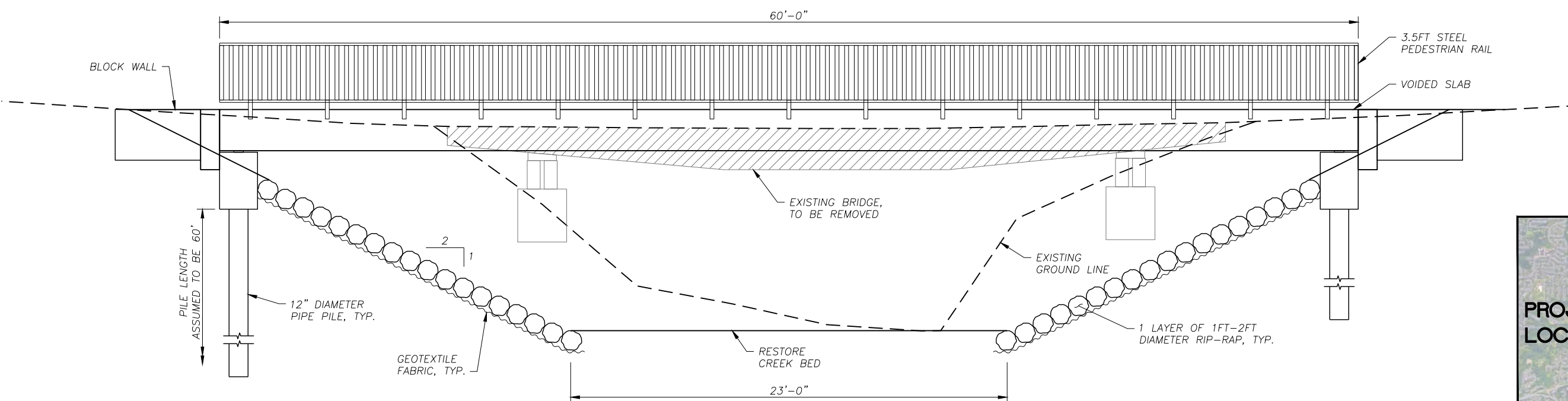

ELEVATION
SCALE: 1"=3'-0"

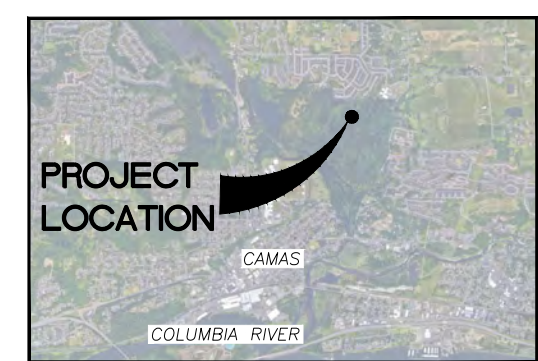

VICINITY MAP
SCALE: NTS
N 45.600948, W 122.390643

LOCATIONS OF EXISTING UTILITIES ARE APPROXIMATE AND MAY BE INCOMPLETE



CONCEPT DRAWINGS
DATE _____

LACAMAS CREEK BRIDGE REPLACEMENT CRP# XXXXXX
LACAMAS CREEK BRIDGE
PRECAST SLAB ALTERNATIVE- PLAN AND ELEVATION

DATE 8/23/2023
S1
1 OF 4

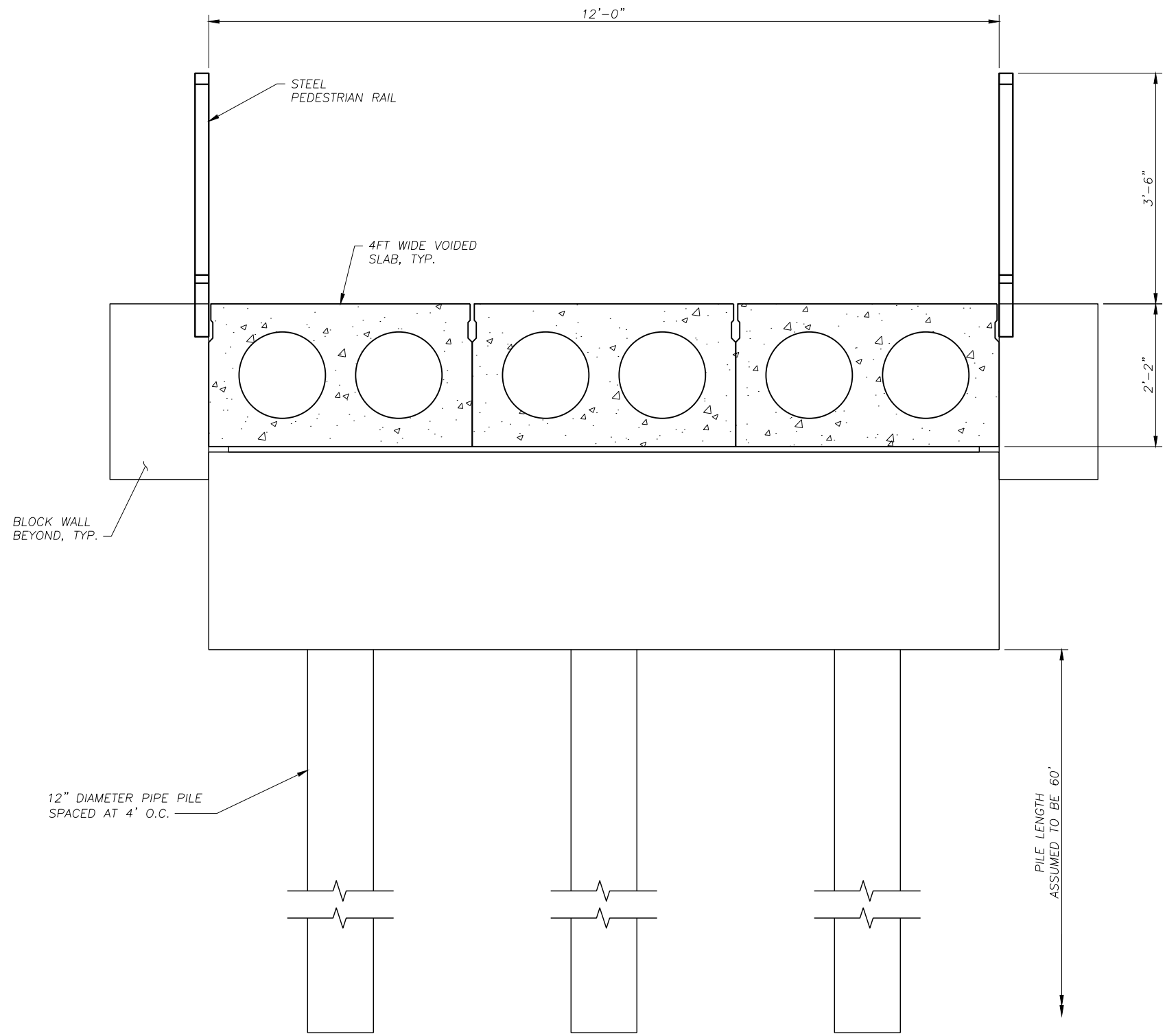

CROSS SECTION
SCALE: 1"=1'-0"

LOCATIONS OF EXISTING UTILITIES ARE APPROXIMATE AND MAY BE INCOMPLETE



CONCEPT DRAWINGS
DATE _____

LACAMAS CREEK BRIDGE REPLACEMENT CRP# XXXXXX

LACAMAS CREEK BRIDGE
PRECAST SLAB ALTERNATIVE

DATE	8/23/2023
	S2
	2 OF 4



JOB DESCRIPTION **LACAMAS CREEK BRIDGE REPLACEMENT OPTION 1**
 CALCULATION FOR **PRECAST PRESRESSED VOIDED SLAB COSTS**

JN.
 BY
 SHEET
 CHECKED BY

VE	DATE	10/17/2023
1	OF	1
IC	DATE	10/19/2023

ITEM NO.	SPEC. SECTION	STD. ITEM NO.	ITEM DESCRIPTION	UNIT	QUANTITY	UNIT PRICE	AMOUNT
PREPARATION							
1		0001	MOBILIZATION	LS		10%	\$36,229
2		0035	CLEARING AND GRUBBING	LS	1	\$2,000.00	\$2,000
3		0050	REMOVAL OF STRUCTURES AND OBSTRUCTIONS	LS	1	\$15,000.00	\$15,000
Drainage							
4		1040	CHANNEL EXCAVATION	CY	357	\$40.00	\$14,293
5		1076	HEAVY LOOSE RIPRAP	CY	74	\$100.00	\$7,431
STRUCTURES							
6			VOIDED SLABS	LF	180	\$900.00	\$162,000
7		4006	STRUCTURE EXCAVATION CLASS A INCL. HAUL	CY	16	\$220.00	\$3,520
8		8376	FURNISHING STEEL PILE TIP OR SHOE 12 IN. DIAM	EA	6	\$225.00	\$1,350
9		4090	FURNISHING ST. PILING 12 IN. DIAM	LF	360	\$110.00	\$39,600
10		4095	DRIVING ST. PILE 12 IN. DIAM	EA	6	\$6,000.00	\$36,000
11		4202	CONC. CLASS 4000 FOR PILE CAPS	CY	5.3	\$1,000.00	\$5,300
12		4202	CONC. CLASS 4000 FOR END DIAPHRAGMS	CY	4.0	\$1,000.00	\$4,000
13		4025	GRAVEL BACKFILL FOR WALL	CY	13	\$100.00	\$1,300
14			MODULAR BLOCK WALL	LS	1	\$8,000.00	\$8,000
EROSION CONTROL AND ROADSIDE RESTORATION							
15		6490	EROSION/WATER POLLUTION CONTROL	EST	1	\$5,000.00	\$5,000
OTHER ITEMS							
16		7736	SPCC Plan	LS	1	\$2,500.00	\$2,500
17		7038	ROADWAY SURVEYING	LS	1	\$10,000.00	\$10,000
18			LANDSCAPING/STREAM RESTORATION	LS	1	\$15,000.00	\$15,000
19		1945	PEDESTRAIN HANDRAIL	LF	120	\$250.00	\$30,000
20		7530	CONSTRUCTION GEOTEXTILE FOR SEPARATION	SY	111	\$5.00	\$555

Construction Subtotal		\$362,849
Contingency	30.0%	\$109,000
Total		\$471,849

Sales Tax	8.7%	\$41,051
Construction Cost Total		\$512,900

Preliminary Engineering	35%	\$179,515
Construction Administration	15%	\$76,935

Total Cost \$769,351

Total Cost (Rounded) \$770,000

Appendix 2
Replacement Option 2 – Prefabricated Steel Truss Bridge
Conceptual Plan and Cost Estimate

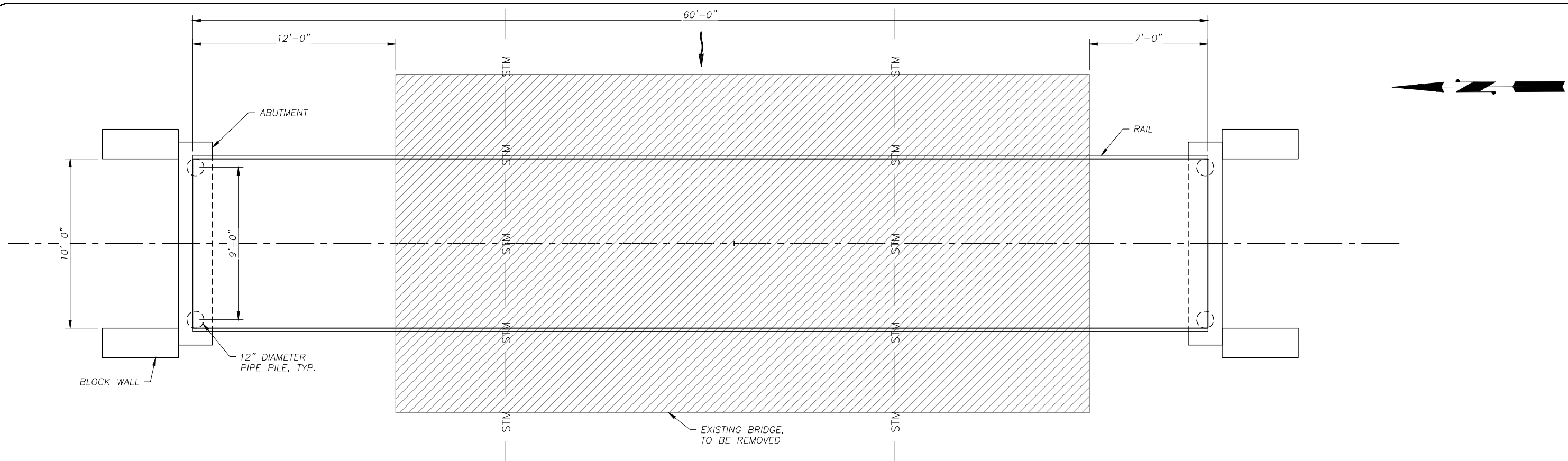

PLAN
SCALE: 1"=3'-0"

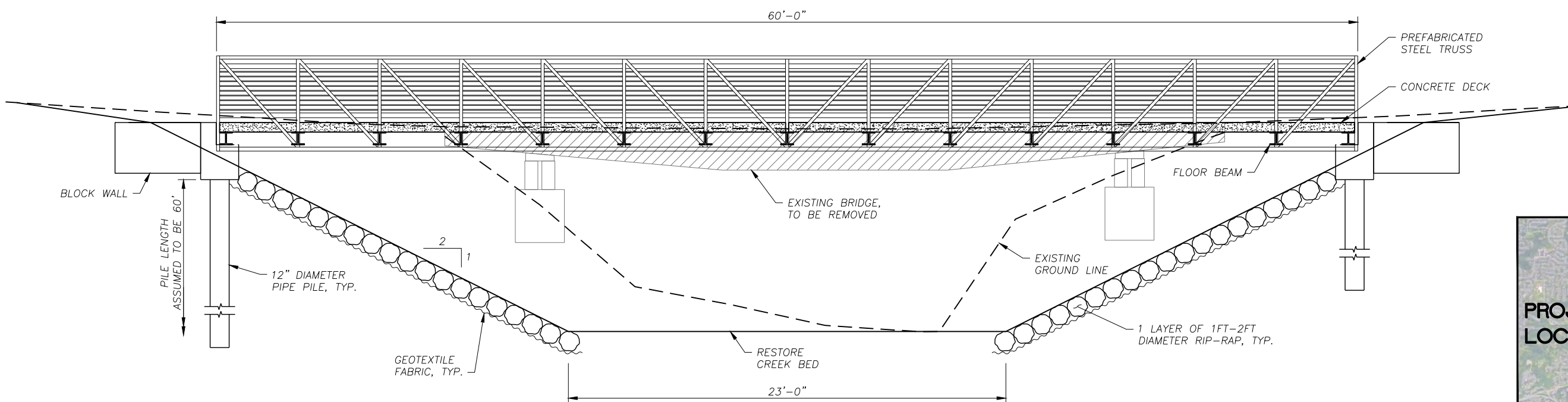

ELEVATION
SCALE: 1"=3'-0"

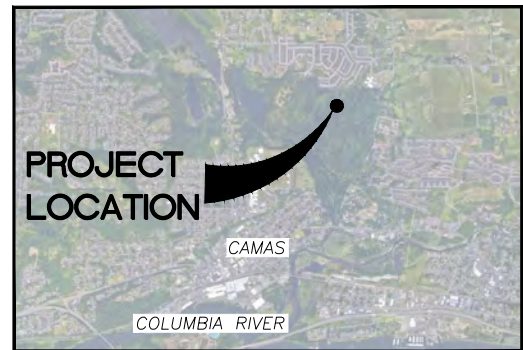

VICINITY MAP
SCALE: NTS
N 45.600948, W 122.390643

LOCATIONS OF EXISTING UTILITIES ARE APPROXIMATE AND MAY BE INCOMPLETE



CONCEPT DRAWINGS
DATE _____

LACAMAS CREEK BRIDGE REPLACEMENT CRP# XXXXXX
LACAMAS CREEK BRIDGE
PREFABRICATED TRUSS ALTERNATIVE

DATE 8/23/2023
S3
3 OF 4

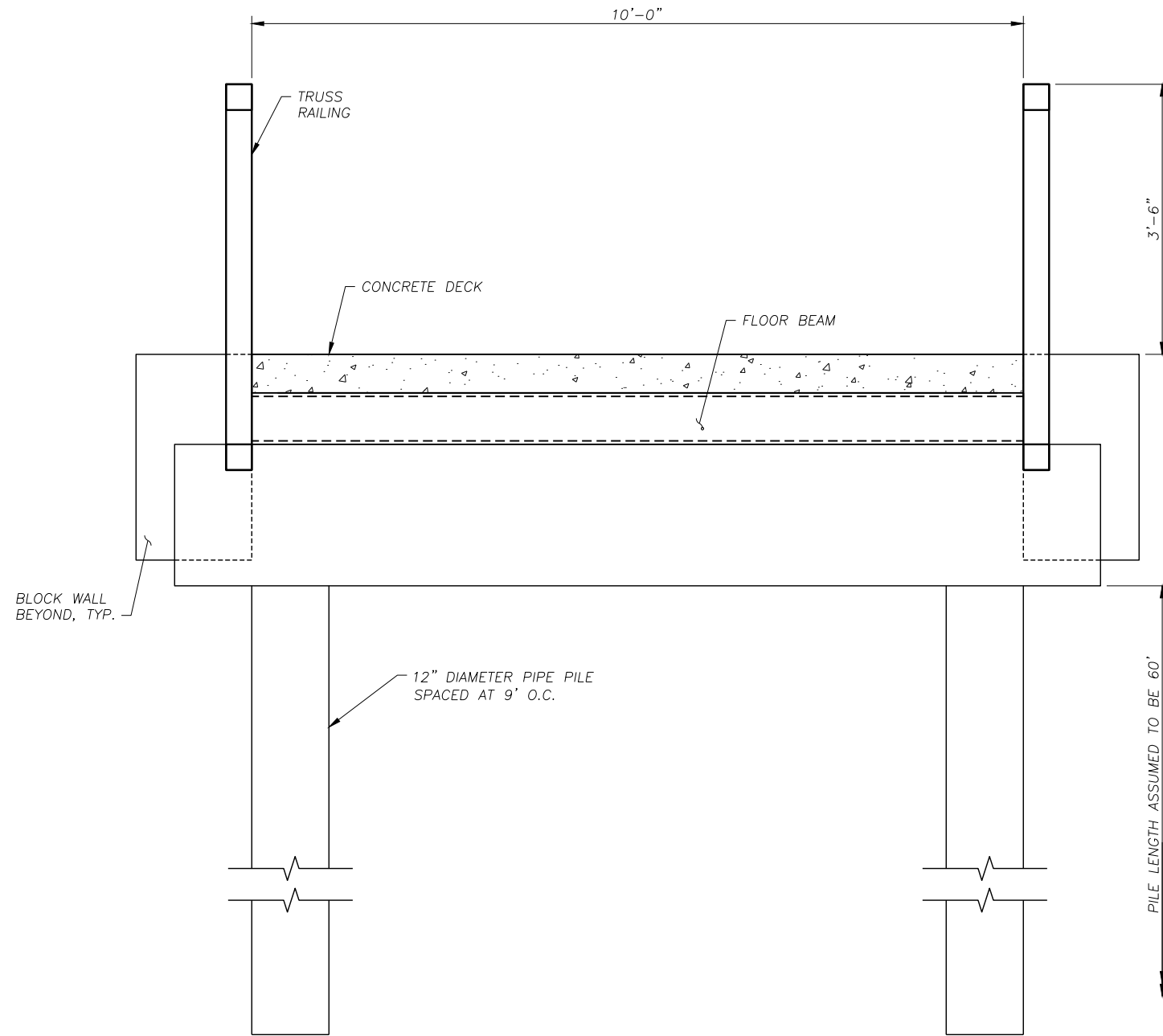

CROSS SECTION
SCALE: 1"=1'-0"

LOCATIONS OF EXISTING UTILITIES ARE APPROXIMATE AND MAY BE INCOMPLETE



CONCEPT DRAWINGS
DATE _____

LACAMAS CREEK BRIDGE REPLACEMENT CRP# XXXXXX

LACAMAS CREEK BRIDGE
PREFABRICATED TRUSS ALTERNATIVE

DATE 8/23/2023
S4
4 OF 4



JOB DESCRIPTION **LACAMAS CREEK BRIDGE REPLACEMENT OPTION 2**
 CALCULATION FOR **PREFARICATED TRUSS COSTS**

JN.
 BY
 SHEET
 CHECKED BY

VE	DATE	10/17/2023
1	OF	1
IC	DATE	10/19/2023

ITEM NO.	SPEC. SECTION	STD. ITEM NO.	ITEM DESCRIPTION	UNIT	QUANTITY	UNIT PRICE	AMOUNT
PREPARATION							
1		0001	MOBILIZATION	LS		10%	\$30,636
2		0035	CLEARING AND GRUBBING	LS	1	\$2,000.00	\$2,000
3		0050	REMOVAL OF STRUCTURES AND OBSTRUCTIONS	LS	1	\$15,000.00	\$15,000
Drainage							
4		1040	CHANNEL EXCAVATION	CY	357	\$40.00	\$14,293
5		1076	HEAVY LOOSE RIPRAP	CY	68	\$100.00	\$6,756
STRUCTURES							
6			STEEL TRUSS	SF	600	\$270.00	\$162,000
7		4006	STRUCTURE EXCAVATION CLASS A INCL. HAUL	CY	18	\$220.00	\$3,911
8		8376	FURNISHING STEEL PILE TIP OR SHOE 12 IN. DIAM	EA	4	\$225.00	\$900
9		4090	FURNISHING ST. PILING 12 IN. DIAM	LF	240	\$110.00	\$26,400
10		4095	DRIVING ST. PILE 12 IN. DIAM	EA	4	\$6,000.00	\$24,000
11		4202	CONC. CLASS 4000 FOR PILE CAPS	CY	6.2	\$1,000.00	\$6,200
12		4202	CONC. CLASS 4000 FOR END DIAPHRAGMS	CY	3.3	\$1,000.00	\$3,300
13		4025	GRAVEL BACKFILL FOR WALL	CY	11	\$100.00	\$1,100
14			MODULAR BLOCK WALL	LS	1	\$8,000.00	\$8,000
EROSION CONTROL AND ROADSIDE RESTORATION							
15		6490	EROSION/WATER POLLUTION CONTROL	EST	1	\$5,000.00	\$5,000
OTHER ITEMS							
16		7736	SPCC Plan	LS	1	\$2,500.00	\$2,500
17		7038	ROADWAY SURVEYING	LS	1	\$10,000.00	\$10,000
18			LANDSCAPING/STREAM RESTORATION	LS	1	\$15,000.00	\$15,000
19		7530	CONSTRUCTION GEOTEXTILE FOR SEPARATION	SY	101	\$5.00	\$505

Construction Subtotal		\$337,501
Contingency	30.0%	\$102,000
Total		\$439,501

Sales Tax	8.7%	\$38,237
Construction Cost Total		\$477,738

Preliminary Engineering	35%	\$167,208
Construction Administration	15%	\$71,661

Total Cost	\$716,606
------------	-----------

Total Cost (Rounded) \$720,000



CLARK COUNTY
WASHINGTON

COMMUNITY DEVELOPMENT

Wetland and Habitat Review Determination Report

Working together. Securing your safety. Protecting your investment.

General Information

Project Name: Lacamas Regional Park - Emergency Vehicular Access Path Extension/Bridge Repair Evaluation

Case Number(s): WHR-2023-00288

Description: Emergency vehicle access into Lacamas Regional Park is currently obstructed by a deteriorated bridge crossing a creek. The Parks and Lands Division is evaluating replacing the bridge, but a new traffic-rated bridge is likely cost prohibitive. An alternative access route is proposed (see attached map) and would be about 120 ft long within the County's park. We request habitat evaluation at both the proposed new route and existing bridge.

Parcel Number(s): 123625000

Site Address(es): Parcel: No primary address specified

Applicant:	Address
Evelyn Ives	1300 Franklin Street Vancouver, WA 98660 USA

Contacts:	Email Address	Phone
Ken Lader	ken.lader@clark.wa.gov	Work - (564) 397-4185

Property Owner:	Address
CLARK COUNTY PARKS	4700 NE 78TH ST, WA, VANCOUVER, 98665

Responsible Staff:	Email	Phone
Watt, Lance	lance.watt@clark.wa.gov	(564) 397-5601

Scope of Determination

Wetland Determination	Y
Habitat Determination	Y
Type S Ordinary High Water Mark Determination	N

Context of Determination

Habitat pre-determination for a future access and bridge replacement in the Lacamas Regional Park.

Analysis

Category Subcategory	Findings
Habitat Determination General	Per County GIS, the subject parcels 123616000, 123625000 have priority non-riparian habitats identified by the Washington Department of Fish and Wildlife as

Biodiversity Area and Corridor. County GIS also indicates a Type F (fish bearing) stream and associated riparian habitat in the vicinity of the proposed bridge replacement. Only the area near the existing access, proposed access and bridge replacement were assessed onsite.

County staff conducted a site visit on October 10, 2023 with the applicant and the Washington Department of Fish and Wildlife to assess what habitat types. County staff identified areas of riparian habitat around the bridge and Biodiversity Area and Corridor, as well as priority snags near the study area as shown in the attached Habitat Determination Map.

The forested portions near the existing and proposed access were confirmed as Biodiversity Area and Corridor by WDFW. These are areas of habitat that are relatively important to various species of native fish and wildlife, typically near a Type F or larger stream/river. The areas are biologically diverse over a landscape scale. They contain habitat that is valuable to fish or wildlife and is mostly comprised of native vegetation. The areas are vertically and horizontally diverse and support a diverse community of species. They include corridors of relatively undisturbed and unbroken tracts of vegetation that connect fish and wildlife habitat conservation areas, priority habitats, areas identified as biologically diverse, or valuable habitats within a city or urban growth area. The forested portions near the stream and existing access met this criteria (shown in red in the attached map). The entire forested section is mapped as biodiversity north of the existing structures, however only the portion around the existing access, bridge and proposed impact was assessed with this review; the remaining forested section is assumed to also meet this criteria.

County staff conducted a site visit and determined the Ordinary High Water Mark (OHWM) as shown in the attached Habitat Determination Map. The site contains a Type F stream on the northeastern portion of the parcel. Only that portion of the Type F stream in or near the proposed development was verified by GPS, the portions up and downstream of the bridge which are shown were estimated based off of historic aerial imagery and local topography.

Per the current County Habitat Ordinance, a Type F stream is protected by a riparian habitat conservation zone which extends outward from the Ordinary High Water Mark to a distance of 200 feet or the edge of the

	<p>100 year floodplain, whichever is greater. In this case the 200 foot line is greater, shown with a blue line. An update to the habitat ordinance is currently in the process of gaining approval which will utilize site potential tree height as recommended by the Washington Department of Fish and Wildlife; County staff have a management recommendation policy document to utilize the WDFW recommendations as best available science in relation to mitigation requirements until the update to the habitat code is finalized. The Olympic clay loam is a Class II soil with a recommended riparian habitat area of 235 feet shown with a light blue dashed line on the map.</p> <p>The applicant shall indicate the location of the stream and priority habitat as shown in the attached map on any future plans relying on this determination.</p>
<p>Habitat Determination General</p>	<p>The Washington Department of Fish and Wildlife define Snags and logs as follows: Trees are considered snags if they are dead or dying and exhibit sufficient decay characteristics to enable cavity excavation/use by wildlife. Priority snags have a diameter at breast height (dbh) of >51 cm (20 inches) in western Washington. Priority logs are > 30 cm (12 inches) in diameter at the largest end and > 6m (20 feet) long. Snags and logs can be found in mature and old-growth forests or unmanaged forests of any age including those in diseased/damaged forests or along riparian areas. Priority snag and/or log habitat includes individual snags/logs or groups of snags/logs of exceptional value to wildlife due to their scarcity or location in a particular landscape. Areas with abundant, well-distributed snags/logs are also considered priority snag habitat. Examples include large sturdy snags adjacent to open water, remnant snags in developed or urbanized settings, and areas with a relatively high density of snags.</p> <p>Any snags or logs, as defined above, shall be preserved in a natural state as they provide valuable habitat for wildlife. The identified snags shall also be shown on any future development plans in order to ascertain potential impacts. Impacts to snags should be avoided to the extent possible.</p>
<p>Wetland Determination General</p>	<p>County GIS indicates modeled National Wetland Inventory wetlands in the vicinity of the mapped Type F stream which continues offsite to the northeast and southwest of the study area. The wetland is identified as R3UBF which stands for an upper perennial riverine wetland which is semi-permanently flooded with an unconsolidated bottom. The historic aerial imagery is inconclusive for potential wetland indicators due to the forested overstory.</p>

	<p>County staff conducted a site visit on October 10, 2023 and did not find evidence of any wetlands associated with the stream. As such, no further wetland review is required.</p>
<p>Avoidance and Minimization General</p>	<p>The Habitat Conservation Ordinance has a hierarchy of impacts, the first choice being avoidance of habitat impacts. In this case there is riparian habitat and priority non-riparian habitat identified as Snags and Biodiversity Area/Corridor habitat on the subject parcel as shown on the provided map. In the event that avoidance is not possible, County staff shall determine if the impacts have been minimized and if the proposed development meets the Avoidance/Minimization standards. The applicant shall provide documentation that any impacts have been minimized. For minimization within riparian habitat, impacts to the outer 50% of the riparian zone are preferred to impacts within the inner 50%; impacts to herbaceous vegetation is preferred to removing woody vegetation. Impacts to Biodiversity Area and Corridor should be avoided, as they are generally considered irreplaceable over a typical mitigation monitoring cycle. Any unavoidable adverse priority habitat impacts shall require a habitat permit and fees with applicable mitigation. Mitigation within priority non-riparian habitat shall be conferred with Washington Fish and Wildlife. The responsible official may waive the requirements of Sections 40.440.010 in certain cases where it is determined that all development is clearly separated from the priority habitat areas or over existing impervious impacts (Table 40.440.010-1); Land division or lot reconfiguration contain habitat areas are exempt if impacted lots establish building and clearing envelopes which are clearly outside of the mapped habitat.</p> <ul style="list-style-type: none"> a) Building envelopes shall be required for a fully complete preliminary application: b) Building envelopes shall be shown on the final site plan; and c) A note referencing the building envelopes shall be placed on the final site plan. <p>The applicant has provided a rough study area which proposes to remove the existing bridge and replace it with a new structure in roughly the same location; the plan also shows a rough corridor for a potential future access. As proposed, it appears that the bridge would be within the riparian habitat and Biodiversity Area/Corridor and could impact some neighboring trees through cutting of trees, limbing of trees, and the required slope setbacks for the footers for the bridge. The new access corridor</p>

was a wide swath for a potential 12 foot wide access. There was holly, blackberry, and low native cover underneath the forested canopy between the offsite stormwater facility and existing path. A new access near the center or west side of the area was preferred as it appeared to have less impact to larger woody vegetation.

Any unavoidable impacts within a priority habitat area (including limbing of existing trees and removal of native trees/shrubs) shall be shown on any future plans and shall require a habitat permit with applicable mitigation.



Determination

Issued: 11/9/2023

This determination is binding on the County for 3 years and is subject to appeal within 14 days of the date it is issued OR within the applicable appeal period of any decision which relies on this determination.

Refer to the attached Determination Map and assessment forms.

Appeal Rights

This Type I decision may be appealed by the applicant, or any other Party of Record, to the County Hearing Examiner. The appeal fee is \$1,166.

Appeals must be filed with the Department of Community Development, Permit Services Center, 1300 Franklin Street, Vancouver, Washington 98668 within fourteen (14) calendar days from the date the notice of final land use decision is mailed to the applicant. Detailed instructions for filing an appeal are available at the Permit Services Center or online at:

<https://www.clark.wa.gov/sites/all/files/community-development/land-use/appeals-motions.pdf>

Appeals must be received at the Permit Services Center by 3:00PM.

Note: The Responsible Official reserves the right to provide additional analysis and findings or fact regarding this decision, if appealed.

<p>The case file for this decision can be reviewed at: Public Service Center Community Development Department</p>	<p>1300 Franklin Street P.O. Box 9810 Vancouver, WA 98666-9810 Phone: (564) 397-2375</p>	<p>A copy of the Clark County Code is also available at: http://www.codepublishing.com/WA/ClarkCounty/</p>
---	---	---

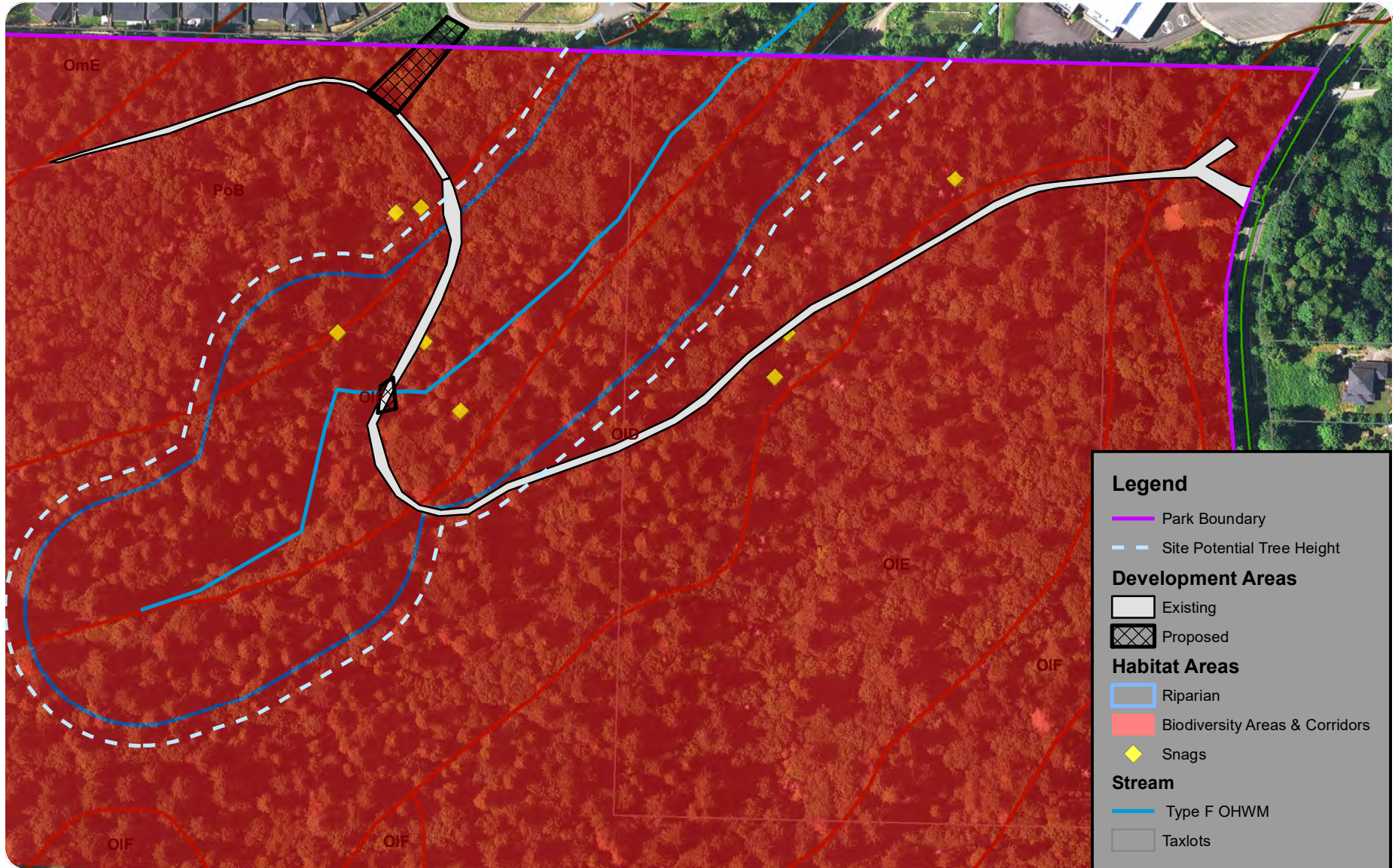

Lacamas Park Emergency Access

WHR-2023-00288

Drawn By:
wattl
Sheet
X of Y
10/10/2023



DRAFT: Lacamas Regional Park Access Path

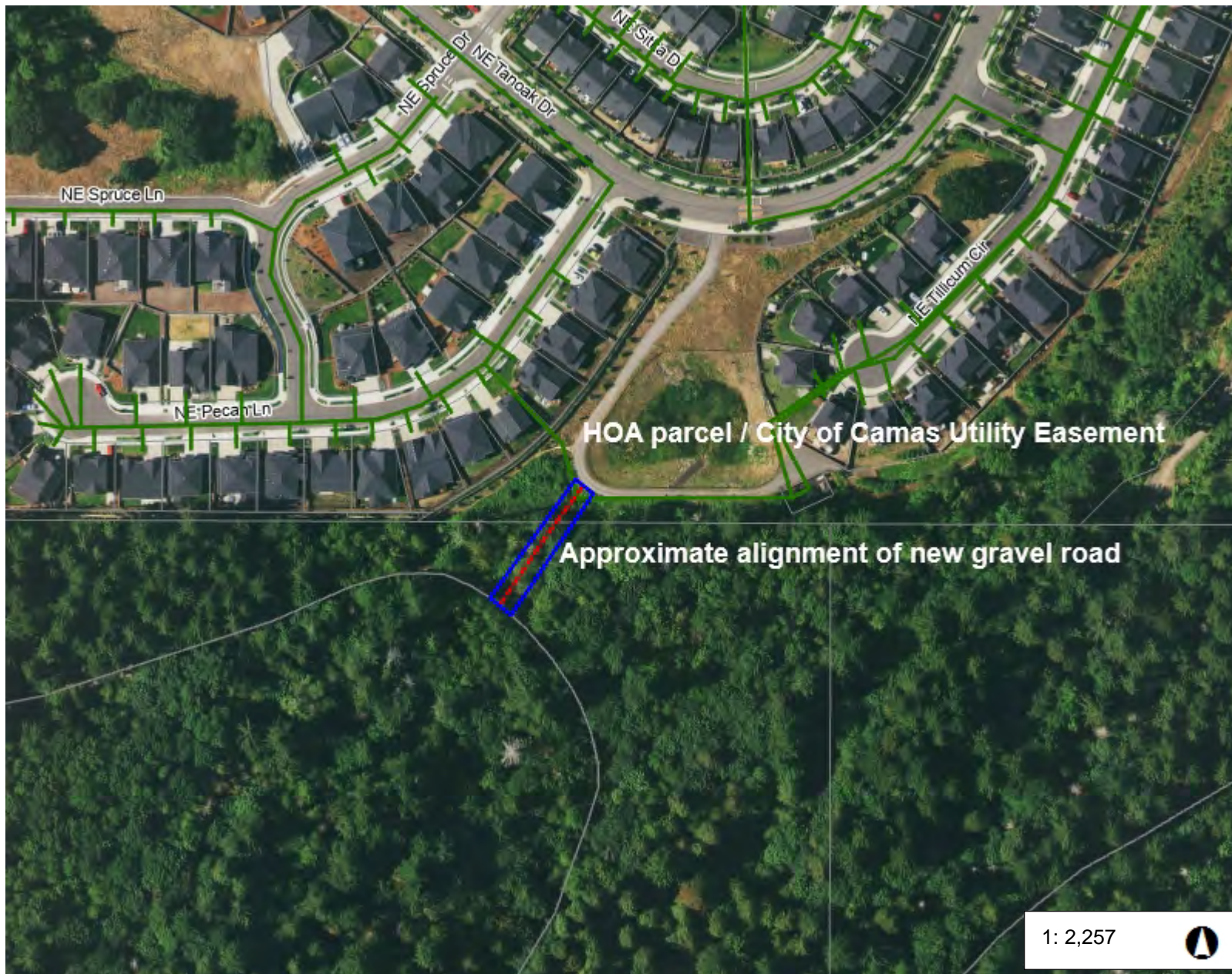

Legend

- Sanitary Sewer
- All Roads**
- Interstate
- State Route
- Arterial
- Forest Arterial
- Minor Collector
- Forest Collector
- Private or Other
- Building Footprints
- Taxlots

Notes:

1: 2,257

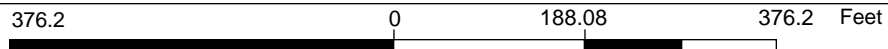

WGS_1984_Web_Mercator_Auxiliary_Sphere
Clark County, WA. GIS - <http://gis.clark.wa.gov>

This map was generated by Clark County's "MapsOnline" website. Clark County does not warrant the accuracy, reliability or timeliness of any information on this map, and shall not be held liable for losses caused by using this information. Taxlot (i.e., parcel) boundaries cannot be used to determine the location of property lines on the ground.



Lacamas Regional Park Bridge

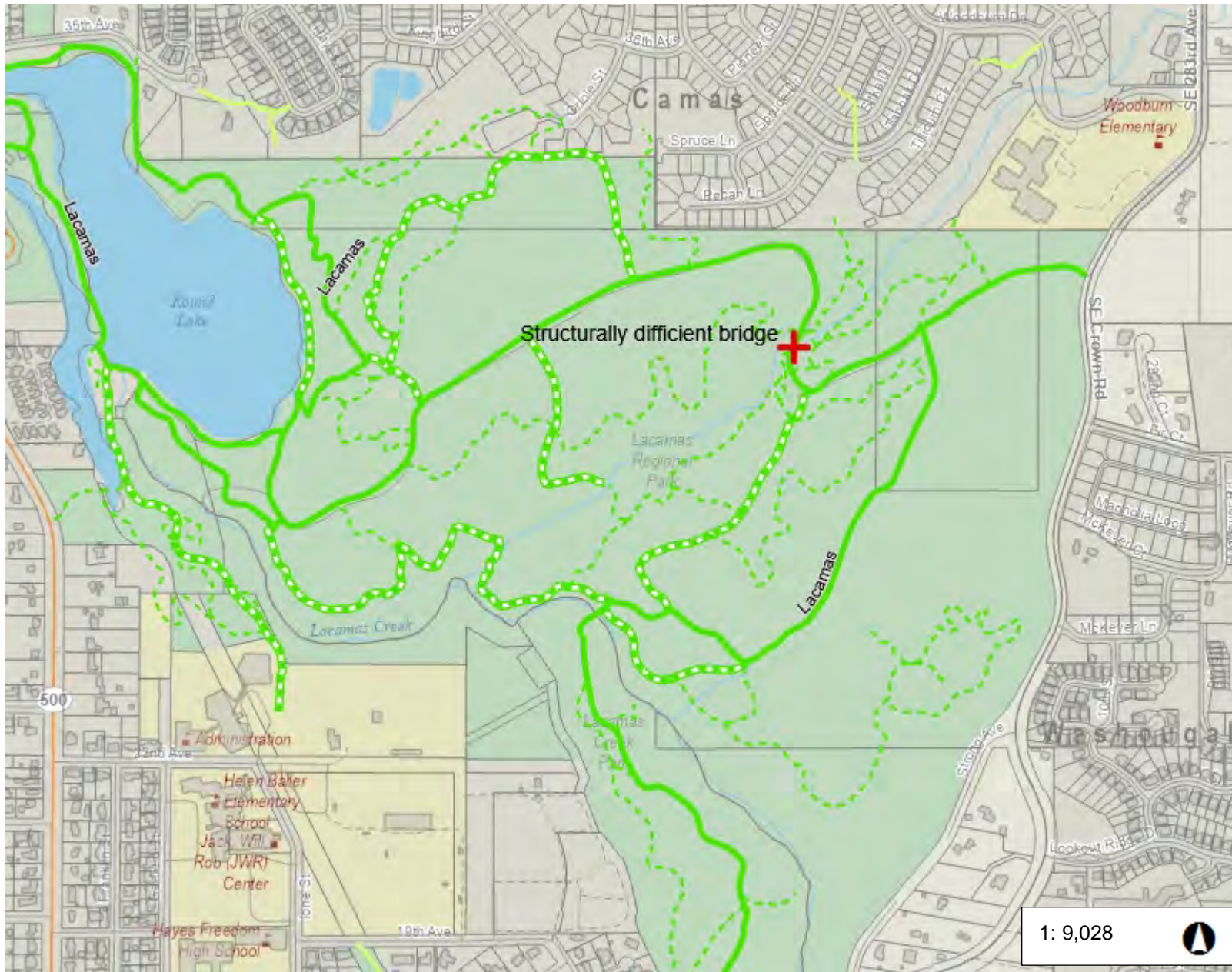

Legend

- Main
- - - Side
- Local
- . . . Primitive
- - - Unknown
- Building Footprints
- Taxlots

Notes:

As of May 23, 2023, no vehicular traffic shall be allowed over the rail car bridge crossing of Lacamas Creek.

1: 9,028

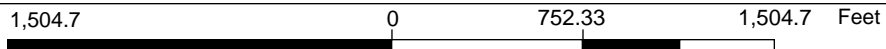

WGS_1984_Web_Mercator_Auxiliary_Sphere
Clark County, WA. GIS - <http://gis.clark.wa.gov>

This map was generated by Clark County's "MapsOnline" website. Clark County does not warrant the accuracy, reliability or timeliness of any information on this map, and shall not be held liable for losses caused by using this information. Taxlot (i.e., parcel) boundaries cannot be used to determine the location of property lines on the ground.

Attachment A

Professional Services Agreement

Agreement Purchase No. _____

THIS AGREEMENT is entered into between CLARK COUNTY, after this called "County," a political subdivision of the State of Washington, and <Example Consultant>, after this called "Consultant".

WITNESSETH

WHEREAS, the Consultant has been chosen through a competitive process, known as the Professional Services Selection Review Process and has the expertise to provide professional services for Clark County as set out in the proposal attached hereto as Exhibit A and incorporated herein by this reference as though set forth in full at this point.

WHEREAS, the County does not have available staff to provide such services for the benefit of the citizens of Clark County,

NOW, THEREFORE, the County and the Consultant mutually agree as follows:

1. Services. The Consultant shall perform services as set forth in Exhibit A.
2. Time. This Agreement shall be effective beginning <DATE> and ending <DATE>.
3. Compensation. Consultant shall submit an invoice on the last day of a month in which any work was performed. Consultant's invoices shall be in accordance with the schedule set forth in Exhibit A and shall reflect all work performed. All invoices shall set forth the project milestones towards which the work was performed (milestones are points at which significant components of the project have been completed and at which tangible project deliverables of material value have been received by the County); and in addition, shall describe in detail each task performed including a breakdown of the amount billed as attributed to each task. The parties mutually agree that in no event shall the amount billed

exceed the dollar amount in Exhibit A without prior written approval of the County.

4. Withholding Payment. In the event the Consultant has failed to perform any substantial obligation to be performed by the Consultant under this Agreement, then the County may, upon written notice, withhold all monies due and payable to Consultant, without penalty, until such failure to perform is cured or otherwise adjudicated.

5. Termination for Default. If the Consultant defaults by failing to perform any of the obligations of this Agreement or cannot perform because of regulatory order or failure to comply with regulatory requirements, including but not limited to applicable licensing laws, or becomes insolvent or is declared bankrupt, commits any act of bankruptcy or insolvency, or makes an assignment for the benefit of creditors, the County may terminate this Agreement, and at the County's option, obtain performance of the work elsewhere. If this Agreement is terminated for default, the Consultant shall not be entitled to receive any further payments under this Agreement. Any extra cost or damage to the County resulting from such default(s) shall be deducted from any money due or coming due to the Consultant. The Consultant shall bear any extra expenses incurred by the County in completing the work, including all increased costs for completing the work, and all damage sustained, or which may be sustained by the County by reason of such default. The waiver by the County of one or more breaches shall not be construed as a waiver of any subsequent breach or breaches. Within fourteen (14) days after termination the Consultant shall provide all work products and working documents developed within the effective term of the Agreement.

6. Termination for Public Convenience. The County may terminate this Agreement upon 30 days written notice to Consultant whenever the County determines, in its sole discretion that such termination is in the interests of the County. Whenever this Agreement is

terminated in accordance with this paragraph, the Consultant shall be entitled to payment for actual work performed at per unit rates for completed items of work. An equitable adjustment in the contract price for partially completed items of work will be made, but such adjustment shall not include provision for loss of anticipated profit on deleted or uncompleted work. Termination of this Agreement by the County at any time during the term, whether for default or convenience, shall not constitute a breach of contract by the County. Within fourteen (14) days after termination the Consultant shall provide all work products and working documents developed within the effective term of the Agreement.

7. Independent Contractor. The Consultant is an independent contractor and not an employee of the County; and as such, the Consultant shall not be entitled to compensation or benefits of any kind except as specifically provided herein.

8. Indemnification / Hold Harmless. The Consultant shall defend, indemnify, and hold harmless the County, its officers, officials, employees and volunteers from any and all claims, injuries, damages, costs, losses or suits, including attorney fees, arising out of, or resulting from, any act or omission undertaken in the performance of this Agreement, negligent or otherwise, of the Consultant, Consultant's employees or agents, Consultant's subcontractors, or Consultant's subcontractors' employees or agents. This indemnification obligation of the Consultant shall not apply if the claim, damage, loss or expense is caused by the sole negligence of the County. In the event of the concurrent negligence of the Consultant (or its employees, agents, or subcontractors), and the County (or its employees or agents), then the obligations of the Consultant set forth in this section shall be valid and enforceable only to the extent of the negligence of the Consultant, its employees, agents, or subcontractors. It is further specifically and expressly understood that the indemnification provided herein

constitutes the Consultant's waiver of immunity under Industrial Insurance, Title 51 RCW, solely for the purposes of this indemnification. The foregoing indemnification obligations of the Consultant are a material inducement to County to enter into this Agreement, are reflected in the Consultant's compensation, and have been mutually negotiated by the parties. The County reserves the right, but not the obligation, to participate in the defense of any claim, damages, losses or expenses and any such participation shall not constitute a waiver of Consultant's indemnity obligations under this Agreement. The provisions of this section shall survive the expiration or termination of this Agreement.

9. Compliance with Laws. The Consultant shall comply with all applicable federal and state wage and hour laws, and any other legislation affecting its employees and the rules and regulations issued thereunder insofar as applicable to its employees, and shall always save the County harmless from all actions, claims, demands and expenses arising out of any alleged violation of said laws and the rules and regulations that are or may be promulgated in connection therewith.

10. Social Security and Other Taxes. The Consultant assumes full responsibility for the payment of all payroll taxes, use, sales, income or other form of taxes, fees, licenses, excises, or payments required by any city, federal or state legislation that is now or may during the term of this Agreement be enacted as to all persons employed by the Consultant in performance of the work pursuant to this Agreement and shall assume exclusive liability therefore, and meet all requirements thereunder pursuant to any rules and regulations that are now enacted or may be promulgated in connection therewith.

11. Order of Precedence. This Agreement consists of these terms and conditions and Exhibit A, which includes a scope of work and provisions relating to Consultant's

compensation. If there is a conflict between the provisions of these terms and conditions and any exhibit or attachment, then the provisions of these terms and conditions shall control.

12. Equal Employment Opportunity. The Consultant will not discriminate against any employee or applicant for employment because of race, color, religion, gender, sexual orientation, age, disability, marital status or national origin.

13. Changes. The County may, from time to time, require changes in the scope of the services to be performed hereunder. Such changes, including any increase or decrease in the amount of the Consultant's compensation, which are mutually agreed upon by and between the County and the Consultant, shall be in writing and signed by both parties.

14. Public Records Act. Notwithstanding the provisions of this Agreement to the contrary, to the extent any record, including any electronic, audio, paper or other media, is required to be kept or indexed as a public record in accordance with the Washington State Public Records Act, RCW Chapter 42.56, or as may hereafter be amended, the Consultant agrees to maintain all records constituting public records and to produce or assist the County in producing such records, within the time frames and parameters set forth in state law. The Consultant further agrees that upon receipt of any written public record request, the Consultant shall, within two business days, notify the County by providing a copy of the request to the Clark County Public Records Officer/Department of Public Works.

15. Governing Law. This Agreement shall be governed by the laws of the State of Washington. Venue for any litigation shall be in accordance with RCW 36.01.050.

16. Confidentiality. With respect to all information relating to the County that is confidential and clearly so designated, the Consultant agrees to keep such information confidential.

17. Conflict of Interest. The Consultant covenants that it has had no interest and shall not acquire any interest, direct or indirect, which would conflict in any manner or degree with the performance of services hereunder. The Consultant further covenants that no person having such interest shall be employed by it, nor shall perform services as an independent contractor with it, in the performance of this Agreement.

18. Liability Insurance. The Consultant specifically confirms and warrants that it has errors and omissions liability insurance with minimum limits of \$1,000,000 per occurrence and in the aggregate for each one-year period. The Consultant specifically confirms and warrants that it has a Commercial General Liability insurance policy with a minimum \$1,000,000 limit. All insurance shall be obtained from an insurance company authorized to do business in the State of Washington.

Waiver of Subrogation: All insurance coverage maintained or procured pursuant to this Agreement shall be endorsed to waive subrogation against the County, its elected or appointed officers, agents, officials, employees and volunteers or shall specifically allow the Consultant, or others providing insurance evidence in compliance with this Agreement, to waive their right of recovery prior to a loss. The Consultant hereby waives its own right of recovery against the County, its elected or appointed officers, agents, officials, employees and volunteers; and shall require proof of insurance coverage, with the same limits as set forth above, in addition to a waiver of subrogation in favor of the County, from each of its subcontractors.

Additional Insured: The County, its elected or appointed officers, agents, officials, employees and volunteers, will be named as additional insured parties on all policies of insurance maintained by the Consultant pertaining to this project, and any policies of

subcontractors, with no restrictions or limitations concerning products and completed operations. This coverage shall be primary coverage and noncontributory to any coverage maintained by the County.

Proof of Insurance: The Consultant shall provide the County with verification of insurance and endorsements required by this Agreement. The County reserves the right to require complete, certified copies of all required insurance policies at any time. Failure to provide proof of insurance within three (3) business days upon demand by the County is agreed by both parties to be a material breach of this Agreement and may result in termination of this Agreement.

19. Entire Agreement. This Agreement contains a complete and integrated understanding of the parties and supersedes any prior understandings, agreements, or negotiations, whether oral or written, unless set forth herein or in written amendments hereto, which are duly executed by both parties.

20. Severability. If any provision of this Agreement is found to be contrary to law or public policy or is declared null and void by a court of competent jurisdiction, the remaining provisions shall remain in full force and effect and binding upon the parties.

21. Waiver. Waiver of any default or breach shall not be deemed to be a waiver of any subsequent default or breach. Any waiver shall not be construed to be a modification of the terms of this Agreement unless stated to be such in writing and signed by the parties hereto or by their authorized representatives.

22. Assignment and Subcontracting. No portion of this Agreement may be assigned or subcontracted to any other individual, firm or entity without the express and prior written approval of the County or as set forth in Exhibit A.

23. Ownership of Items Produced. All writings, documents, programs, records or other materials prepared by the Consultant and/or its subcontractors, in connection with the performance of this Agreement shall be the sole and absolute property of the County.

24. Notice. Except as set forth elsewhere in the Agreement, for all purposes under this Agreement, except service of process, notice shall be given by the Consultant to the County via: Ken Lader, Director of Public Works, 1300 Franklin Street, Vancouver, WA 98660. Notice to the Consultant for all purposes under this Agreement may be sent to Consultant's address as reflected on invoices or correspondence received from the Consultant. Notice may be given by delivery or by depositing in the US Mail, first class, postage prepaid.

IN WITNESS HEREOF, the County and the Consultant have executed this Agreement on the last date written below.

Signed this ___ day of _____, 2023

Signed this ___ day of _____, 2023

CLARK COUNTY

<CONSULTANT NAME>

By: Kathleen Otto, County Manager

By

Printed Name

Approved as to form only:

Title

ANTHONY F. GOLIK
Clark County Prosecuting Attorney

By: Kevin A. McDowell

Deputy Prosecuting Attorney

EXAMPLE